

BOSS MICRO RACK SERIES

RBF-10 **FLANGER**

INSTRUCTIONS

FEATURE

The BOSS Flanger RBF-10 features three basic Modulation Controls and Normal/Invert Feedback Volume, allowing various flanging effects. Also, with the direct sound cut off, this can be set up with a PA mixer to make an effect loop. Moreover, two sets of the RBF-10's can be connected through the Modulation Buses for sync'ing. Both standard phone and pin jacks are provided for wider variations of applications. The RBF-10 is one of the BOSS Micro Rack Series, and any two of the Micro Rack Series can be mounted on the standard 19" rack (EIA-1U) by using the optional rack mount adaptor RAD-10.

- Please read the instructions carefully.

Radio and television interference

“Warning – This equipment has been verified to comply with the limits for a Class B computing device, pursuant to Subpart J, of Part 15, of FCC rules. Operation with non-certified or non-verified equipment is likely to result in interference to radio and TV reception.”

The equipment described in this manual generates and uses radio-frequency energy. If it is not installed and used properly, that is, in strict accordance with our instructions, it may cause interference with radio and television reception.

This equipment has been tested and found to comply with the limits for a Class B computing device in accordance with the specifications in Subpart J, of Part 15, of FCC Rules. These rules are designed to provide reasonable protection against such an interference in a residential installation.

However, there is no guarantee that the interference will not occur in a particular installation. If this equipment does cause interference to radio or television reception, which can be determined by turning the equipment on and off, the user is encouraged to try to correct the interference by the following measure:

- Disconnect other devices and their input/output cables one at a time. If the interference stops, it is caused by either the other device or its I/O cable.

These devices usually require Roland designated shielded I/O cables. For Roland devices, you can obtain the proper shielded cable from your dealer. For non Roland devices, contact the manufacturer or dealer for assistance.

If your equipment does cause interference to radio or television reception, you can try to correct the interference by using one or more of the following measures:

- Turn the TV or radio antenna until the interference stops.
- Move the equipment to one side or the other of the TV or radio.
- Move the equipment farther away from the TV or radio.
- Plug the equipment into an outlet that is on a different circuit than the TV or radio. (That is, make certain the equipment and the radio or television set are on circuits controlled by different circuit breakers or fuses.)
- Consider installing a rooftop television antenna with coaxial cable lead-in between the antenna and TV.

If necessary, you should consult your dealer or an experienced radio/television technician for additional suggestions. You may find helpful the following booklet prepared by the Federal Communications Commission:

“How to Identify and Resolve Radio-TV Interference Problems”

This booklet is available from the U.S. Government Printing Office, Washington, D.C., 20402, Stock No. 004-000-00345-4.

PANEL DESCRIPTION

< FRONT PANEL >

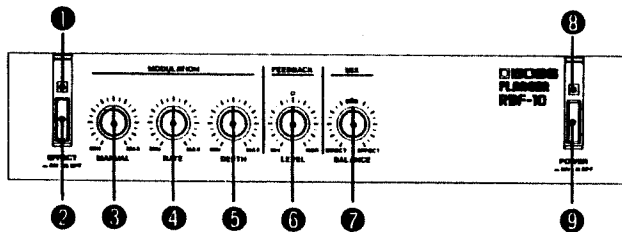

① EFFECT INDICATOR

This lights up when the effect is turned on. So you can easily see whether the unit is in the Normal or Effect mode.

② EFFECT SWITCH

Each time this switch is pushed, the unit is alternately turned to the Effect and Normal mode.

③ MANUAL

Use this knob to select a center frequency of the flanging effect. As you rotate this clockwise, the frequency will become higher.

④ RATE

This knob controls the speed of the flanging effect. Rotating this clockwise quickens the effect.

⑤ DEPTH

This knob controls the depth of the flanging modulation. Rotating this clockwise deepens the

effect.

- With this knob rotated fully clockwise, the Manual Knob does not work at all.

⑥ FEEDBACK

This knob controls the amount of feedback signal in normal or inverted phase. At the center position, the feedback level is zero, and turning the knob clockwise will increase the feedback level of the normal phase. And rotating it counterclockwise will increase the feedback level of the inverted phase, emphasizing the flanging effect.

⑦ BALANCE

This adjust the amount of the direct and effect sound. At the center position, the mixing balance is equal, making the strongest flanging effect.

- When using the RBF-10 for making an effect loop with the device such as PA mixer, set the Balance Knob fully clockwise.

⑧ POWER INDICATOR

This lights up when the unit is turned on.

⑨ POWER SWITCH

< REAR PANEL >

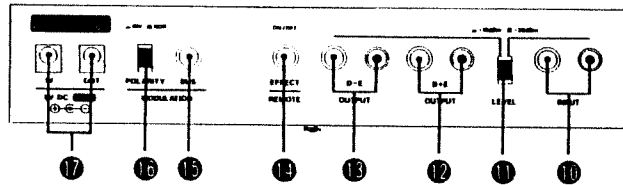

⑩ INPUT JACKS

Connect a musical instrument or audio equipment to this jack.

- * The standard phone and pin jacks do not work at a time. If both are simultaneously used, the standard phone jack will have priority.

⑪ LEVEL SWITCH

Set this knob to an appropriate position depending on the output level of the connected device. “-20dBm” position may be selected for a usual electric musical instrument (such as an electric guitar), and “-10dBm” position for audio equipment.

⑫ D+E OUTPUT JACKS

Through this jack, the mixture of direct sound and effect sound of the normal phase is sent out.

⑬ D-E OUTPUT JACKS

Through this jack, the mixture of direct sound and effect sound of the inverted phase is sent out.

- * The standard and the pin jacks of the D+E and D-E Outputs can be used at a time.

⑭ EFFECT REMOTE JACK

Connect the footswitch FS-1 (optional) to this jack, and Effect/Normal mode can be selected without reaching out your hand.

- * The above function cannot be obtained if the Effect Switch on the front panel is turned off. When two RBF-10's are setup, connect the Remote Jacks of the two units, and Effect/Normal of the two units can be controlled by either of them.

⑮ MODULATION BUS JACK

When you setup two RBF-10's to obtain stereo effect, use this jack to sync the modulations of the two RBF-10's. (See “MODULATION BUS”)

⑯ POLARITY SWITCH

When two RBF-10's are set up, the polarity of either RBF can be inverted with this switch.

- * When the Polarity Switch is set to “INV”, the Manual Switch affects invertedly, too.

⑰ AC ADAPTOR JACKS

This is to connect the AC Adaptor (BOSS PSA-120, 220 or 240). Connect the adaptor to IN. When using this unit to supply power to other BOSS Micro Rack Series, connect the supplied DC cord to OUT.

- * When only one AC adaptor is used for supplying power to more than one unit, please be sure that the total amount of the current draw does not exceed 200mA. (The current draw is shown on the rear panel of each unit.)

■ CONNECTIONS

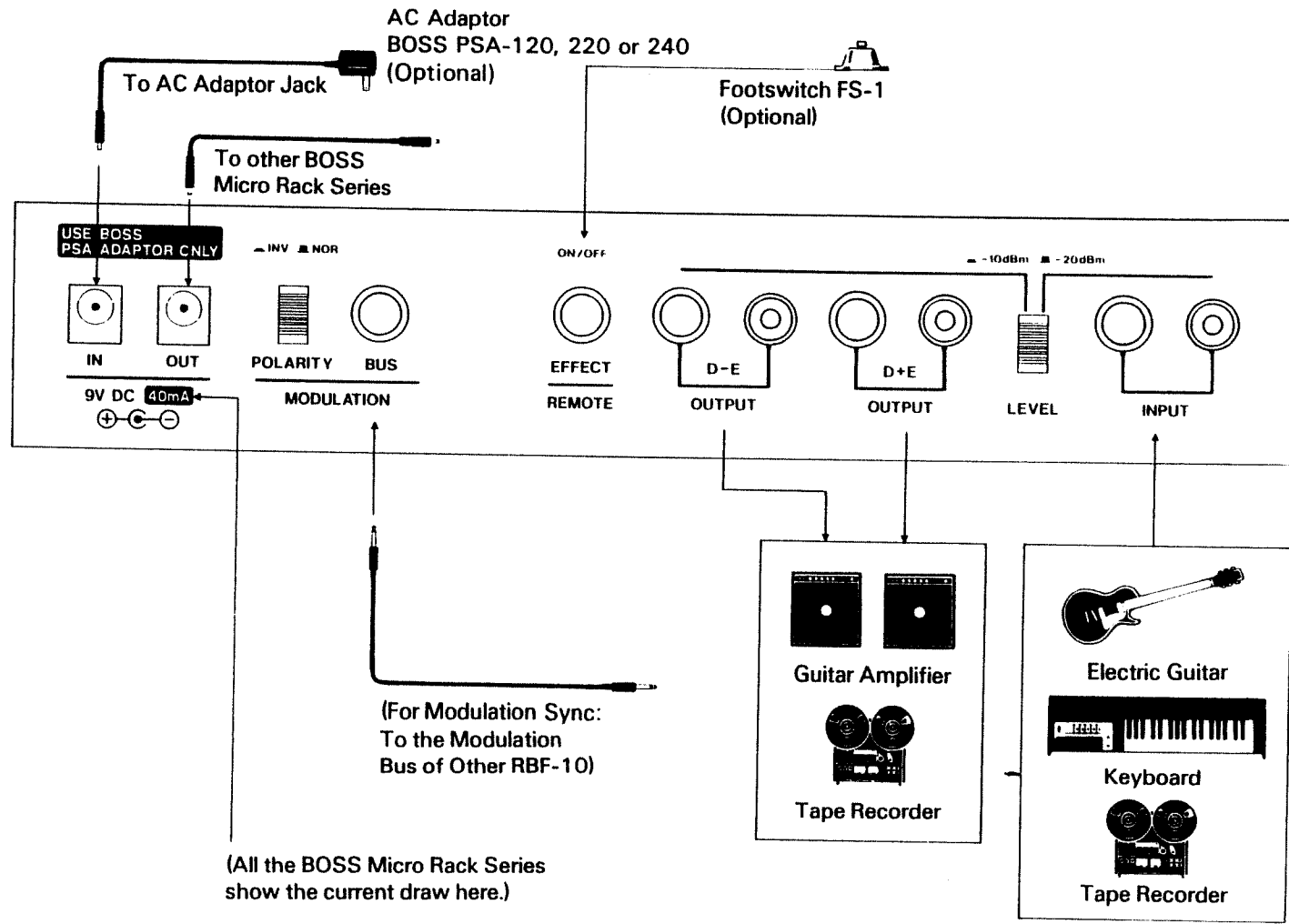

■ OPERATION

1 Set the knobs on the panel as shown below.

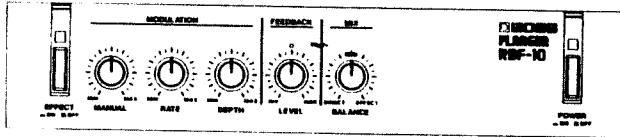

2 Set the Level Switch to the appropriate position depending on the output level of the connected unit.

*If it is the noise that you wish to avoid more than anything, set the switch to “-20dBm” position. Changing the position of the Level Switch will not affect the volume.

3 Rotate the Rate Knob to adjust the speed of the flanging effect.

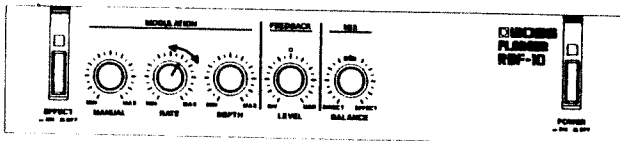

4 Rotate the Manual and the Depth Knobs to adjust the depth of the effect.

* When the Depth Knob is turned fully clockwise, the Manual Knob does not work at all.

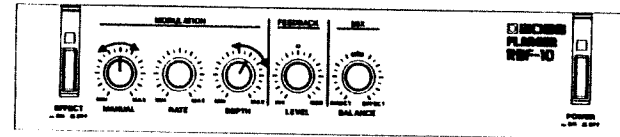

5 To emphasize the flanging effect, rotate the Feedback Knob. At the center position, chorus like effect is obtained.

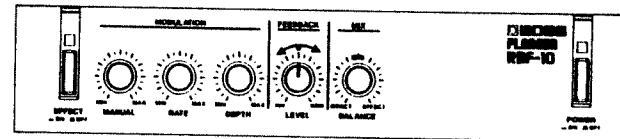

6 By connecting a footswitch to the Effect Remote Jack, Normal/Effect can be changed without reaching out your hand.

* Make sure that the Effect Switch on the front panel is turned on.

■ MODULATION BUS

By connecting two RBF-10's through their Modulation Buses, stereo flanging effect can be obtained.

1 Set up two RBF-10's as shown below.

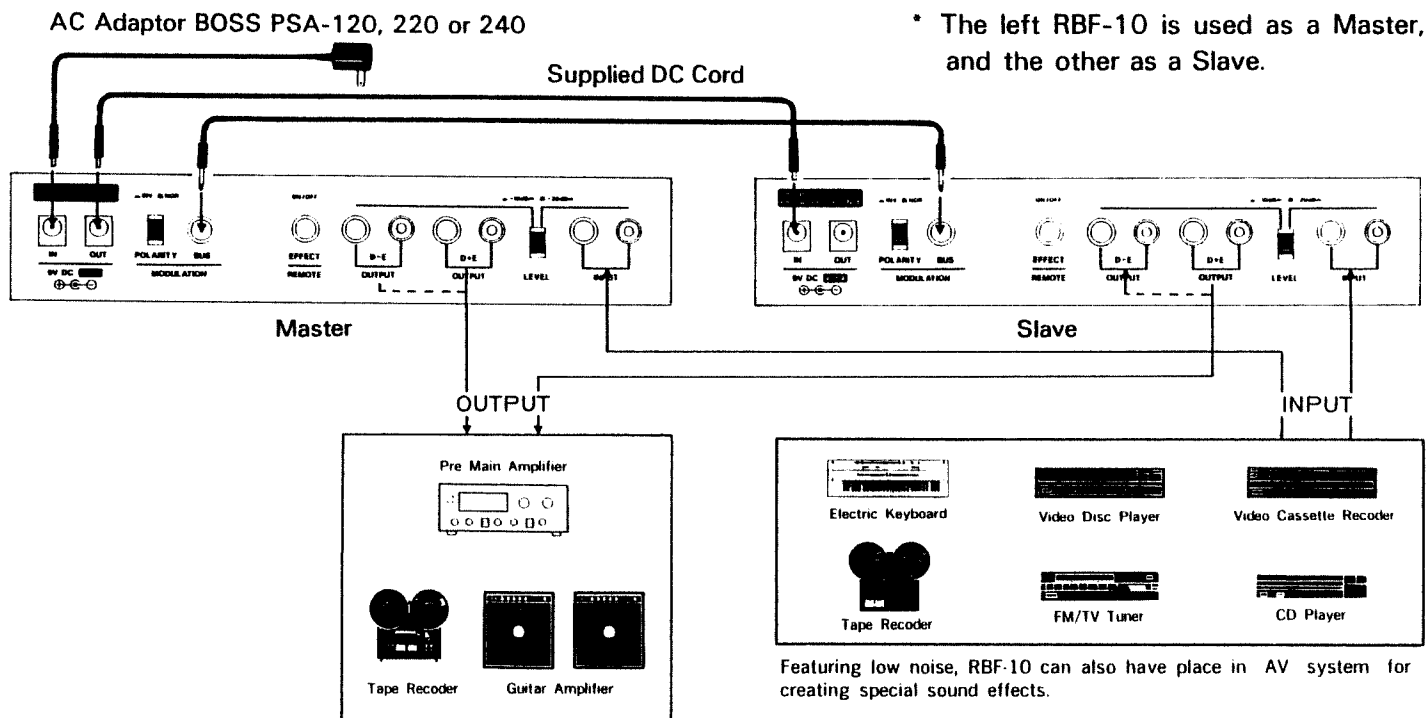

2 Set the knobs on the front panel as shown below.

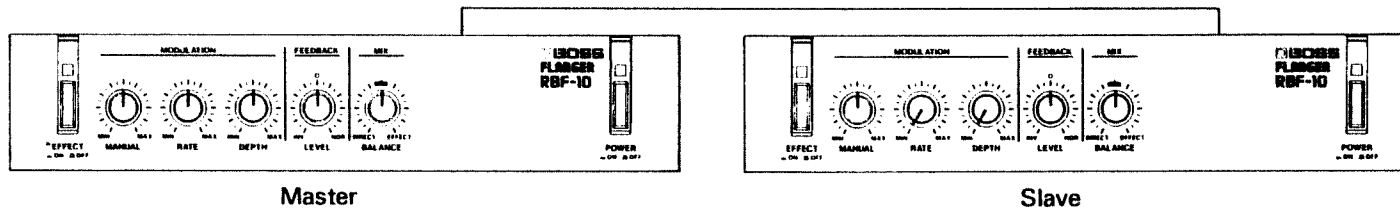

- * To avoid excessive amount of two mixed modulation, set the Manual Knob on the Slave unit to the center position, and the Depth Knob to the MIN position. With the Depth set to the MIN position, the Rate Knob has no effect.

3 Adjust the Manual, Rate and Depth Knobs of the Master unit to your taste.

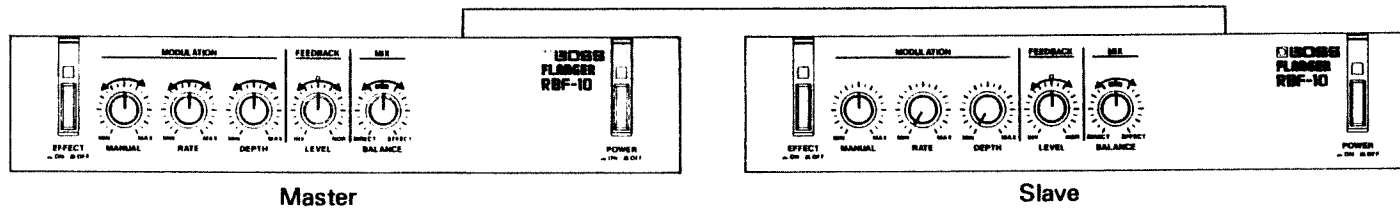

4 To obtain more effective stereo effect, invert the polarity of the modulation on either unit.

■ NOTES

- Be sure to use the BOSS AC Adaptor PSA-120, 220 or 240 depending on the line voltage system in your country.
- When you are using only an AC adaptor for supplying power to more than one unit, please be sure that the total current draw does not exceed 200mA.
- Avoid operating this unit in excessive heat or humidity or where it may be affected by dust.
- Please never remove the cabinet from the unit.
- When you use only Micro Rack Series without optional Rack Mount Adaptor "RAD-10", please attach the rubber feet. Refer to figure.

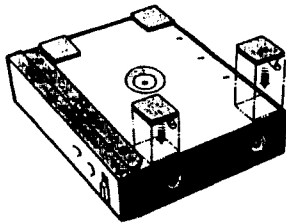

■ AC ADAPTOR:

BOSS PSA-120, 220 or 240 (Optional)

Be sure to use the Adaptor BOSS PSA-Series. Using any other type of adaptor may cause trouble.

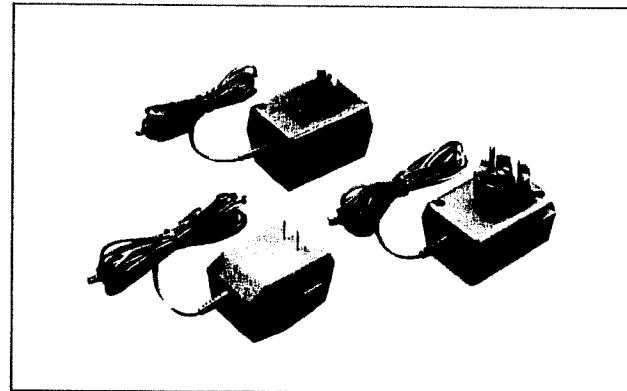

■ RACK MOUNTING

The RBF-10 is one of the BOSS Micro Rack Series, and any two of them can be mounted in a standard 19" rack (EIA-1U) by using the optional Rack Mount Adaptor RAD-10.

Remove the rubber feet on the bottom of the units, fix each of them on the Rack Mount Adaptor with the supplied screws, then place it on the rack.

SPECIFICATIONS

Input Level/Input Impedance:
- 20dBm/1M Ω , - 10dBm/47k Ω

Output level/Output Impedance:
- 20dBm/2k Ω , - 10dBm/2k Ω

Gain: UNITY (0dB)

Output Load Impedance:
Over 10k Ω

Frequency Response:
At Effect Off: 15Hz to 60kHz (± 3 dB)

Residual Noise:
At Effect Off: - 100dBm
At Effect On: - 98dBm
(with the IHF-A, Level Switch set to - 20dBm)

Delay Time: 0.4ms~3.2ms

LFO Rate: 100ms to 16s

Controls: Manual Knob
Rate Knob
Depth Knob
Feedback Knob
Balance Knob

Switches: Power Switch
Effect Switch (Normal/Effect)
Level (- 20dBm/- 10dBm)
Polarity (Normal/Invert)

Jacks: Input (Standard, Pin)
D + E Output (Standard, Pin)
D - E Output (Standard, Pin)
Effect Remote (On/Off)
Modulation Bus
AC Adaptor (In, Out)

Indicators: Power Indicator
Effect Indicator

Power: 9V DC (BOSS PAS-120, 220 or 240)

Current Draw: 40mA

Dimensions: 218(W) x 44(H) x 169(D) mm
(8-9/16" x 1-3/4" x 6-11/16")

Weight: 900g/2 lb

Accessory: DC Cord (0.5m)

OPTIONS

AC Adaptor: BOSS PSA-120, 220 or 240

Rack Mount Adaptor: RAD-10

Footswitch: FS-1

Micro System Rack: BMR-5

Specifications are subject to change without notice.

BOSS Micro Rack Series	
RCL-10	Compressor/Limiter
RBF-10	Flanger
RGE-10	Graphic Equalizer
RPH-10	Phaser
RDD-10	Digital Delay



Products of Roland
Printed in Japan '85 Jun. C-3



10430

UPC 10430

