

# **DRUMULATOR SERVICE MANUAL**

**Version 1.0  
11 April 1983**

© E-mu Systems Inc.  
1983

# **DRUMULATOR SERVICE MANUAL**

VERSION 1.0

Drumulator, Emulator and E-mu are trademarks of E-mu Systems, Inc.  
©1983 by E-mu Systems, Inc., Santa Cruz, Ca. All rights reserved.

---

## Table of Contents

---

1.	SUMMARY OF FUNCTIONS AND CONTROLS	5
2.	COMPUTER INTERFACE SPECIFICATIONS	9
3.	THEORY OF OPERATION	11
4.	TEST PROCEDURE	17
5.	DEBUGGING PROCEDURE	21
6.	SCHEMATICS	27
7.	SIGNAL NAME DEFINITIONS	63
8.	SPECIFICATIONS	67
9.	E.C.O.s	69
10.	SERVICE CENTERS	71
11.	SILKSCREEN LEGEND	73
12.	PAD PROGRAMMER OPERATING INSTRUCTIONS THEORY OF OPERATION , SCHEMATICS	74

# 1 Summary of Functions and Controls

---

The following is a short-form summary of the various Drumulator functions. For more information, refer to the indicated section number in the Drumulator Owner's Manual.

## SEGMENT MODE FUNCTIONS (unless noted otherwise, the SEGMENT light should be lit)

1C Assigning standard Drum Sounds to Play Buttons: Choose drums or perc. mode. Hold down any Drum Play button, and continue holding it down while you tap the desired Drum/Percussion Sound Select button.

1C Assigning accented Drum Sounds to Play Buttons: Hold down the Drum Play button to be assigned and tap **ACCENT**. While continuing to hold down the Drum Play button, press the Drum Select button which corresponds to the drum or percussion sound you want accented.

1D Setting Drum/Percussion Levels: Press **LEVEL**. Press the desired Drum/Percussion Sound Select button. Vary the slider. When you reach the desired level, press **ENTER**.

1D Resetting All Drum/Percussion Levels to 0: Press **LEVEL** once to enter level mode; then press and hold **LEVEL** and press **ENTER**. A beep confirms this operation.

1E Setting Drum/Percussion Accents: Assign the sound to be accented to a Drum Play button (Section 1C). Press **ACCENT**, then the Drum Sound Select button you want to accent. Move the slider. When you reach the desired accent, press **ENTER**.

1F Playing Back Segments: Press one of the numbered buttons 1-6 to select the bank, then press one of these buttons to select the segment number. Press **RUN/STOP** to start the segment.

1F Setting tempo: Press **TEMPO**. Vary the slider to select the new tempo. When you find the right tempo, press **ENTER**.

1G Programming the metronome: Press **MET/TRIG**. Press one of the six metronome select buttons (8, 8/3, 16, 16/3, 32, 32/3) then press **ENTER**. Or, press **MET/TRIG** again for quarter note clicks.

2B Erasing a Segment: While holding down **ERASE**, press the desired bank number, key in the segment number, then press **ENTER**. A beep confirms that the segment has been erased.

2C Setting time signature: To set the time signature denominator, press **MEAS. LENGTH**. Press **>** to increase, **<** to decrease the denominator value. After reaching the right value, press **ENTER**. you are now ready to set the time signature numerator. Press **>** to increase, **<** to decrease the numerator value. Press **ENTER**.

2C Setting segment length: Press **SEG. LENGTH**. Press **>** to increase, **<** to decrease the number of measures per segment. After reaching the right value, press **ENTER**.

2C Real time segment length setting: Press **SEG. LENGTH** then **RUN/STOP**. After the appropriate number of measures have gone by, as indicated by the display, tap **RUN/STOP** a second time.

2E Setting Auto Correct: Press **AUTO CORRECT**. Press one of the 6 Auto Correct buttons (8, 8/3, 16, 16/3, 32, 32/3), then press **ENTER**. To select high resolution mode, press **AUTO CORRECT** twice and then press **ENTER**.

2F Recording a Segment: While holding down **RECORD**, push **RUN/STOP** so that the **RUN/STOP** light glows. Play the various drums where you want them to occur in the segment. When you've finished recording, press **RUN/STOP** again to stop the segment.

2F Recording a Segment, Assign Mode: While in record mode, press the **RECORD** button. The left-hand display will read **AS** (for assign). You are now temporarily out of record mode and can reassign sounds to the Drum Play buttons. To continue recording, press **RECORD** again.

2G Erasing a Specific Drum Sound: The Drumulator must be stopped. While holding down **ERASE**, tap the Drum Play button which triggers the sound you want to erase, and while still holding down **ERASE**, press **ENTER**. A short beep will confirm that the drum has been erased.

2H Erasing a Specific Note of a Drum Track: The Drumulator must be running and in record mode. While holding down **ERASE**, tap the Drum Play button which triggers the sound you want to erase on the note or notes you want to erase, or hold the Drum Play button down continuously to erase several consecutive beats of a drum sound.

2I Copying Segments: The Drumulator must be stopped. Key in the bank/segment you want to copy. Press **COPY**. Key in the number of the segment you want to copy to, then press **ENTER** to complete the copying procedure. A beep will confirm a successful copy.

2J Appending a Segment: The Drumulator must be stopped. Key in the bank/segment you want to append. Press **COPY**. Key in the same bank/segment number, select the number of times to be appended (1-8), then press **ENTER**. A beep will confirm a successful append.

2K Adding Swing: The Drumulator must be stopped. Press **SWING**; press buttons 1-6 to select the desired swing factor, then press **ENTER**.

2L Checking Memory Space: The Drumulator must be stopped. Press **MEM**. Display shows amount of remaining memory, expressed as a percentage.

**3P Clearing all Data: While holding ERASE tap CASSETTE. While continuing to hold ERASE, press ENTER. A beep confirms that the data has been erased.**

**SONG MODE FUNCTIONS** (Unless noted otherwise, the SONG light should be lit)

3B Selecting a Song: While holding down **SELECT**, press one of the lower row of eight numbered buttons.

3C Chaining Segments Together: Select the song you want to program. Key in the bank number of the first segment, then the segment number. Press **ENTER** or **>**. Key in the next bank/segment number, press **ENTER** or **<**, and continue keying in the various segment numbers until the entire song has been entered.

3D Ending a Song (repeating the song indefinitely): When you reach the last step of the song press **END**, then press **REPEAT**.

3D Ending a Song (proceeding to another song after the first song has ended): When you reach the last step of the song press **END**. Next, press one of the lower row of numbered keys (**1-8**) to select the song number to which you want to jump.

3D Ending a Song (unconditional end): When you reach the last step of the song press **END**, then press **END** a second time.

3D How to Erase a Song: Enter an unconditional end at step 1 of the song by pressing **END** twice.

3E Editing Songs (stepping): Locate the step by using the **<** and **>** buttons to make the appropriate change.

3E Editing Songs (inserting): To insert an additional step, locate the step number where you want the insert. Press **INSERT**. All subsequent steps are automatically renumbered to reflect the addition of the inserted step; you may now key in the instruction for the new step. After entering the instruction, press **ENTER**.

3E Editing Songs (deleting): Locate the step you want to delete, then press **DELETE**. All subsequent steps are automatically renumbered to reflect this deletion. To delete more steps, continue pressing **DELETE**.

3F Using Repeats: Press **REPEAT** at the step where the repeat should begin. Press **REPEAT** again at the step where the repeat should end, then enter the number of times you want the repeat to occur using the lower row of numbered keys (**1-8**). If you want the repeat to continue indefinitely, press **REPEAT** again instead of entering a number. After keying in this step, press **ENTER** to enter the instruction into the Drumulator's memory.

3F Exiting from a Repeat Loop: You may exit from a repeat loop before you are scheduled to leave it by pressing **REPEAT** (or using a footswitch, as described in Section 5A). As soon as the repeating segment(s) has finished playing, the Drumulator will proceed to the next step in the song.

3G Programming Song Drum Sound Levels: Press **LEVEL**. Press the Drum/Percussion Sound Select button corresponding to the sound you want to vary, adjust the slider to vary the drum level from 0 to 15, then press the next Drum/Percussion Sound Select button whose level you want to program. After adjusting the level of the last Drum/Percussion Sound Select button you want to change, press **ENTER**.

3H Setting Drum/Percussion Accents: Press **ACCENT**. Press the Drum/Percussion Sound Select button corresponding to the sound whose accent you want to vary, adjust the slider to vary the accent level from 0 to 15, then press the next Drum/Percussion Sound Select button whose accent you want to adjust. After adjusting the accent of the last Drum/Percussion Sound Select button you want to change, press **ENTER**.

3I Setting Song Tempo: Press **TEMPO**. Vary the slider to select the new tempo. When you find the right tempo, press **ENTER**.

3J Copying Segment Parameters to a Song: After perfecting the segment level/accent parameters, switch over to song mode. Hold down **SELECT** and press the appropriate numbered button (1 - 8) to select a song. While continuing to hold down **SELECT**, tap **LEVEL**. You will hear a beep to confirm that the transfer has taken place.

3K Copying Song Parameters to a Different Song: While in song mode, select the song whose parameters you want to copy over to another song. Hold down **SELECT** and press the appropriate numbered button (1 - 8) to select the song to which you want to copy the level and accent information. While continuing to hold down **SELECT**, tap **LEVEL**. A beep will confirm a successful transfer.

3L Programming Tempo Changes Within a Song (assigning tempo changes to the number buttons): Assign tempo changes to the buttons numbered 1 through 8 by first pressing **TEMPO** twice. Press button 1, then move the slider to find the appropriate amount of tempo change (expressed as a percentage). Next, either press **ENTER** to end this first part of the tempo change procedure, or press 2 to program a second tempo change in a manner similar to the above. You may program up to 8 tempo changes. After presetting the various tempo changes, press **ENTER**.

3L Programming Tempo Changes Within a Song (inserting these changes into a song): When you reach the song step where you want the tempo change to occur, while holding **SELECT** press **TEMPO**. Enter the number (1-8) which corresponds to the desired amount of tempo change, then press **ENTER**.

3L Programming Tempo Changes Within a Song (returning to the original tempo): When you reach the song step where you want the tempo change to occur, while holding **SELECT** press **TEMPO**. Press **TEMPO** a second time, then press **ENTER** to enter this step into the Drumulator's memory.

3M Programming Trigger Outputs (starting the pulse train): When you reach the song step where you want the pulses to start, press **MET/TRIG**. Press 1 for 8th note pulses, 2 for 8th note triplet pulses, etc.—just like programming Auto Correct. Press **ENTER** to enter the "pulse train start" instruction into the Drumulator's memory.

3M Programming Trigger Outputs (stopping the pulse train): When you reach the song step where you want the pulses to end, press **MET/TRIG**, press **MET/TRIG** a second time, then press **ENTER** to enter the "pulse train stop" instruction into the Drumulator's memory.

3N Starting in the Middle of a Song: Use the > and < keys to locate the step at which you want to start. Hold down **SELECT**, then tap **RUN/STOP**.

**CASSETTE INTERFACE FUNCTIONS** (in any of these steps, make sure you are in cassette mode by pressing **CASSETTE** so that the display shows **CASS** and the CASSETTE light glows)

4B Saving Drumulator Data on Tape: Make sure levels are correct, then put tape recorder into record mode. Roll tape. Press **SAVE** to send the Drumulator song and segment data to the recorder. Make at least 3 saves to guard against defective tape.

4C Verifying Saved Data: Rewind the tape recorder to just before where the saved data is recorded. While holding **SAVE**, tap **LOAD**, then release both buttons. Put the tape recorder into play mode. After the data has finished playing back, the right display will (hopefully!) show **GOOD** to indicate that the data has been properly stored on tape. If the right display shows **bAd**, it means that the data was not saved properly.

4D Loading Data from Tape into the Drumulator: Rewind the tape recorder to just before where the saved data is recorded. Press **LOAD**. Put the tape recorder into play mode. After the data has finished playing back, the CASSETTE light will glow continuously, and the right display will (hopefully!) show **GOOD**. This means that the data has been properly loaded into the Drumulator. If the right display shows **bAd**, it means that a problem occurred while loading the data.

4D Loading a Single Segment into the Drumulator: Follow the above procedure but when it comes time to press **LOAD**, press and hold **LOAD** and, while continuing to hold **LOAD**, use buttons 1-6 to key in the number of the segment you want to load.

#### **CONTROL JACK FUNCTIONS**

5A Footswitch Jacks, **RUN/STOP** jack: A footswitch plugged into this jack duplicates the **RUN/STOP** switch. Press once to run, press again to stop.

5A Footswitch Jacks, **REPEAT** jack: When the Drumulator is running and in a repeat loop, pressing a footswitch plugged into this jack gets you out of the repeat.

5B Met/Trig Output: In segment mode, the metronome signal appears at the **MET/TRIG** out jack, with the level being independent of the **METRONOME VOLUME** control. In song mode, any triggers which you programmed to appear during the course of a song appear at this jack.

5C Gate Inputs: Gate inputs **GATE A** through **GATE D** accept trigger pulses (the kind generated by many sequencers, drum units, and so on) to trigger the drum sounds assigned to Drum Play buttons A-D, respectively.

5E Recording a Sync Track on Tape: Patch the **CLK/CAS OUT** jack to a tape recorder channel. Set levels properly. Put the recorder into record mode, roll tape, and press **RUN/STOP**.

5F Recovering the Drumulator's Sync Track from Tape: Patch the output of the recorder channel containing the sync track to the **CLK/CAS IN** jack. Rewind the tape to the period of silence just before the sync track starts. Press **EXTERNAL CLOCK**, then press **RUN/STOP**. Roll tape. To return to normal after the sync track ends, stop the Drumulator, then press **EXTERNAL CLOCK**. The EXTERNAL CLOCK light will go out.

5G Using the Drumulator with 24 Pulses Per Quarter Note Clocks: Connect a patch cord from the other unit's clock output to the Drumulator's **CLK/CAS IN** jack. Press **EXTERNAL CLOCK**, put the Drumulator into run mode, then start the other unit's clock. To return to normal after the external clock ends, stop the Drumulator, then press **EXTERNAL CLOCK**.

5H Using the Drumulator with 48 or 96 Pulses Per Quarter Note Clocks and Audio Rate Clocks: Patch the other unit's clock output to the Drumulator's **CLK/CAS IN** jack. To accept a 48 pulses/quarter note clock, while holding down **EXTERNAL CLOCK** use the **>** and **<** controls to change the number in the right hand readout to **02**. To accept a 96 pulses/quarter note clock, while holding down **EXTERNAL CLOCK** use the **>** and **<** controls to change the number in the right hand readout to **04**. To accept an audio rate clock, choose the appropriate divisor using the **>** and **<** keys. To return to normal after the external clock ends, stop the Drumulator, then press **EXTERNAL CLOCK**.

#### MISCELLANEOUS FUNCTIONS

Determining Software Revision Number: Occasionally, computer software will contain "bugs". These are software errors which only show up under certain specific or unusual conditions (like a cat walking across the keys), and thus are not always found before a unit is released for production. While every effort has been made to track down these bugs, no one's perfect. If you encounter one of these bugs and contact either your dealer or E-mu about the problem, you will be asked for the Software Revision Number so we can determine whether updated software exists which corrects the problem. To find out the software revision number, while holding down **MEM**, press and hold **CASSETTE**. The rev number will appear in the display.

Unimplemented instructions: E-mu is working on additional Drumulator features, including a pad programmer and an RS-232 interface to allow control by an external computer. At the moment, these functions are not implemented. However, if you press certain keys, you may discover these instructions. While holding down **EXTERNAL CLOCK**, if you press and hold **RECORD** the display says **PADS**. To get out of pads mode, press either **EXTERNAL CLOCK** or **CASSETTE**. To then exit from these modes (if appropriate), again press whichever button you pushed to return to normal.

If, while holding down **EXTERNAL CLOCK**, you press and hold **RUN/STOP**, the entire unit will go dead, thereby preparing the Drumulator to be controlled via an external computer. Hit **ENTER** to restore the Drumulator to normal operation.

## 2 Drumulator External Computer Interface Specifications

Revision of 19 May 83

The Drumulator was designed as a low cost digital drum machine with a minimum of expensive frills. As a result, the hardware contains no provision for external control, such as a parallel or serial port (nor is there any extra board space for such a component). However, due to popular demand, we have decided to add a feature for the computer hobbyist, allowing you to completely control the Drumulator sound generator via your external computer.

The External Computer feature comes standard with all Drumulators, and allows the unit to accept a 9600 baud, 8 bit serial RS-232C signal such as typically supplied by standard microcomputer serial interfaces. The format and connection details will be given below.

To enter External Computer Control mode, press and hold the EXT CLK button on the Drumulator (the display will read EC 01 or something close), then press RUN/STOP. The Drumulator will appear to completely die—all LEDs will go out. This is because the computer is so busy looking for data it can't do anything else (we never claimed it was a brilliant CPU). However, it will now faithfully respond to any serial data you might send it. Note that depending upon the national debt and the phase of the moon, the first byte you send to the Drumulator in this mode may give an erroneous sound, so send a test byte before doing serious work.

To exit External Computer Control mode, press ENTER.

The recommended connection between your RS-232C cable and the Drumulator is given below. Note that the Drumulator needs only the serial output from the computer—all other signals are ignored. The signals interconnected on the computer connector are so placed because some UARTS require certain signals to be 'true' to operate.

### COMPUTER RS-232C CONNECTOR

PIN	NAME		DRUMULATOR
1	Protective Ground	_____ nc	
2	Serial Output	_____	Clk/Cass IN
3	Serial Input	_____ nc	
4	Request to Send	_____	
5	Clear to Send	_____	
6	Data Set Ready	_____	
20	Data Terminal Ready	_____	
7	Signal Ground	_____	Shield Gound

The data format required by the External Computer Control mode is an 8 bit serial data format. Because the Drumulator CPU is both controlling the sound generator and interpreting the serial data, two stop bits (or a parity bit and 1 stop bit) are required in between data bytes. This can generally be accomplished by programming the UART appropriately. Graphically, the data sent will be:



Because RS-232C is an inverting data format, the data shown above would be 01010101 binary or 55 hexadecimal.



The data format required by the Drumulator is interpreted to give a sound and level for each byte sent. The sound is initiated during the 2 stop bit interval following data transmission. The most significant 4 bits indicate the level of the sound, and the least significant 4 bits determine the sound to be made, according to the following table:

LS 4 Bits (hex)	SOUND
0	Clave
1	Cowbell
2	Claps
3	Open Hi Hat
4	Closed Hi Hat
5	Ride Cymbal
6	Bass Drum
7	Snare Drum
8	Rimshot
9	Hi Tom
A	Mid Tom
B	Low Tom
C	Metronome Click
D	Ignored
E	Ignored
F	Ignored

Note that the metronome click ignores the level data, and that the click will last about 2 msecs, preventing re-triggering during this time.

Hence sending the data string 37H, ABH, OCH would produce a snare drum at volume level 3, a low tom at volume level 10, and a metronome click.

E-mu would be interested in hearing about any uses you make of this interface. Please contact the marketing department about any useful programs you have created, or with any questions.

## 3 Drumulator Theory of Operation

---

The Drumulator is a computer controlled digital synthesizer designed specifically to produce digitally recorded drum sounds using relatively inexpensive hardware. This has been accomplished by making extensive use of software, both by the main Z-80 CPU, and by the special purpose register file controller. As a result, the theory of operation of many of the Drumulator functional blocks requires an understanding of both the hardware and the effective function of the driving software. SEE PAGE 29

The major force behind the Drumulator is a Z-80 microprocessor, which controls a number of peripheral circuits. This is illustrated in the block diagram. We'll discuss each block in detail, concentrating on the theory of operation of the individual block, with a short section on how it relates to the whole.

### POWER SUPPLY

The power supply generates a variety of power sources used for the analog and digital circuitry of the Drumulator. It also generates two status signals to guarantee data retention in the non-volatile Memory during power up and power down.

The on-board power switch and fuse route the AC to the transformer; note the 115/230 VAC switch. Capacitor C-104 to some extent filters out RF energy pulses that might sneak in from the line and upset the processor.

The transformer produces 10VAC to be full-wave rectified into the raw +V supply (about 12V under load) used for the LED array and regulated by an LM323 to +5 volts for the logic. It also produces 36VAC center-tapped to be full wave rectified and used to generate the regulated +15 and -15 supplies for the analog circuitry. VR6 and the VPP supply are not used in current Drumulator revisions, although there is space for them on the circuit board.

C22, the 10 uF capacitor associated with the LM323, is necessary for stability during power-up and power-down. C25, associated with the 7915-15 regulator, is also required for stability.

The CA3086 transistor array is used to detect valid power conditions. When the +V supply (unregulated +5) reaches about 7.5 volts, the anode of zener diode D54 will be near 1.3 volts, turning transistor 3-4-5 on. This in turn will unsaturate transistor 1-2-3, allowing signal +50K to become true. This is used to terminate the "reset" signal to the Z-80 processor. At the same time, the CMOS compatible signal +PWROK will become true, allowing writing of the non-volatile memory. Note that a low line condition will cause many processor resets to occur, preventing anything but the first few pages of code to be executed.

The lithium battery supplies, through D3, 3V power to the non-volatile RAM during power-off. Regulator VR1 produces 5.6 volts, dropped to 5V by diode D1, for the non-volatile RAM during operation.

### Z-80 CPU

The Z-80 CPU runs the show. It fetches instructions from the program ROM, manipulates data using the scratch pad and non-volatile RAMS, and sends it to the various input/output functions.

The Z-80 CPU requires a clock to operate. The PHI clock for the Drumulator runs at 2.5 MHz. This is generated from a 5 MHz crystal oscillator by a counter. The counter also generates a 833 KHz clock called CLK.

The Z-80 CPU also needs the RESET signal high before it will do anything useful.

The Z-80 CPU must decide whom it is talking to, and to do this it uses a 74LS138 decoder. The outputs select which of several output latches are the destination of CPU I/O Write data. The Z-80 uses some SSI gates to select the pushbutton read function CSRPB to do an I/O read.

The Z-80 accepts an interrupt signal from the Z-80 CTC. This signal is extensively used by the Drumulator for virtually every function. It will be discussed in more detail under the Z-80 CTC section.

### PROGRAM ROM

The Drumulator software resides primarily in the program ROM, a 2764 EPROM. This software will undoubtedly be occasionally revised, so be sure you know the software 'Rev number' which can be obtained by pressing MEM-CASS if the instrument runs, or the 'Release date', which is a number like 830405 on the EPROM label. This will be necessary when considering software bugs or talking to us for help.

The EPROM simply responds to a select condition, when both its OE and CE pins are brought low, with the 8 bits of data specified by the 13 bits of address. Note, by the way, that the EPROM is copyrighted. Should you need to make a copy of it for service reasons, please ask for our written permission.

#### **SCRATCHPAD RAM**

The Drumulator requires a certain amount of general memory to accomplish its function. This read/write memory is two 2114 RAMs. They will respond with data specified by address when their CS inputs are low and their WE inputs are high. They will accept data at the address when CS is low and WE is low.

#### **NON-VOLATILE RAM**

The Drumulator's permanent memory, where it saves all the segments, songs, and mixes, is in two battery backed-up 6116 CMOS memories. Note that these are placed in 28 pin sockets—this is in case we decide to use another component here. In the meantime, the power is supplied through a special +5M circuit that always stays on—either from a regulator or battery. It responds with data when CS and OE are low, and accepts data when CS and WE are low. Note, however, that CS is generated by a 4023 NAND gate that also gets its power from +5M, and accepts a signal PWROK so that the NV RAMS can only be selected when the power is on. The RAMS and CMOS IC typically draw about 2 microamps of current from the battery when power is off.

#### **METRONOME**

The Drumulator produces a metronome by simply triggering a one-shot that makes a 2 msec pulse, perceived as a click. To make an accented click, we send several. To make a beep, we send a bunch. Simple, huh. This signal goes directly to the output and through a volume pot into the mixer.

#### **SYNC/CASSETTE OUTPUT**

The Drumulator generates data for sync and cassette entirely in software, and simply outputs the data into a latch. Hence the synch output just takes the data bit value from DO whenever the CPU sends it (CSWSYNC), and remembers it 'till next time.

#### **DISPLAY**

The Drumulator display is a multiplexed display using high (12V) voltage drivers. It is driven by the CPU on timing generated by CTC interrupts. Hence this stuff must work before you'll see much of anything.

The CPU first turns off all 8 cathode drivers by writing 0 to the 74LS273 display latch (CSWDISP). The ULN2803 turns off current to all LEDs. The CPU then selects the next anode by writing the appropriate bits to the display select latch (CSWPBL bits 3,4,5), which the 74LS145 decodes and drives the appropriate transistor into saturation. Note the transistors float on +V, a ripply signal. The appropriate LED group anode is thus pulled high. Finally, the CPU writes the correct data for this LED group to the display latch, and current is supplied to the appropriate segments for about 1.6 msec., when we begin the process again (we're lucky Z-80's are easily bored).

#### **PUSHBUTTONS**

The Drumulator pushbuttons are scanned by the same interrupt-driven routine that runs the multiplexed LED display. The routine is similar. First the CPU notes by selecting the data input port CSRPB which of the 4 pushbuttons currently selected were pushed, and which were released. It then sends to the pushbutton latch (CSWPBL bits 0,1,2) a code representing the next group to be selected. The 74LS42 selects that group. The diodes on the pushbuttons prevent pressing two at once from confusing the processor.

#### **EXTERNAL INPUTS AND FOOTSWITCHES**

The external gate inputs and footswitches are scanned by the CPU just like pushbuttons. However, since these signals are simply voltages presented by external devices, a transistor is required to convert the signal into the equivalent of a switch.

In the case of the external gate inputs, a positive voltage at the input allows the transistor to saturate when the bus is selected, simulating a pushbutton.

In the case of the footswitches, the transistor's base is normally supplied with current, so the equivalent 'pushbutton' looks to the CPU like it is pressed until the footswitch is closed, bringing the base to ground and making the transistorized 'pushbutton' appear unpressed. Fortunately for us, the clever designers of the Drumulator figured out this apparent twist of logic and convinced the CPU to behave exactly the opposite of normal, that is to execute the footswitch function when the 'pushbutton' appears open.

## **Z-80 CTC**

Up until now, things probably have seemed to be pretty normal and like most microprocessor systems. The Z-80 CTC, however, adds what are called multi-level interrupts to the system, and they can occasionally get a little hairy. A description of the interrupt process will probably help.

When the Drumulator starts up, it realizes that it should do certain things periodically (like update the multiplexed display and recall sequence data). So it programs the CTC to remind it by a tap on the interrupt line every so often. When the CTC interrupts the CPU, the CTC takes the IEO line low (a useful debugging aid for interrupt system problems) and the interrupt line low. The CPU then 'acknowledges' the interrupt, which tells the CTC to bring the interrupt line high again (but leave IEO low), and then the CPU executes the program it needed to be reminded to do. When that program is completed, the CPU 'returns' from the interrupt routine. The CTC is smart enough to notice this, and then brings the IEO line high. Hence: if the INT line stays low the CPU is never acknowledging the interrupt (this is done by bringing IORQ and M1 low simultaneously), and if INT is high but IEO stays low, the CPU is never finishing the routine (probably incorrectly reading the program ROM).

If all this has bewildered you, remember, things could be worse. Try the register file section if you don't believe me.

Anyway, the CTC is used primarily for the LED and pushbutton scan interrupt and the sequencer timing interrupt. This takes up two channels of the CTC.

A third channel is used as a counter to interpret the slider. Every scan cycle (about 1.6 msec), the CPU triggers the slider one-shot (CSWPOT), which then generates a pulse that varies in length from about 10 to 400 usec. This then gates the 833 KHz clock into the counter, which has been programmed to count the pulses that get through. The result is that the CPU knows the resistance of the slider.

The fourth channel is used by the sync and cassette functions (and the pad and external computer modes). The sync input is 'conditioned' by an op-amp connected in a non-inverting amplifier mode with hysteresis. This neatly squares up the ugly signals generally supplied by cassettes. This signal is then limited in swing by D48 and D49 to avoid injuring the already abused CTC. The CTC can then interrupt the processor on the rising or falling edge of the signal. The processor can look at the state of the signal using CSRPB, but it never bothers.

The cassette interface works entirely by measuring the timing of the edges supplied to it (timing is everything—right?). This means that if the timing gets screwed up, usually by a bad slew rate or insufficient gain anywhere along the way, it won't read properly.

## **REGISTER FILE CONTROLLER**

All of the stuff up to now may have been fascinating, but doesn't have much to do with music, huh. Well this doesn't either, but it does explain where the sound comes from. So listen carefully.

The Drumulator's sound generator is really a special purpose processor that has its own program (called microcode) and all the other things processors like (such as registers, clocks, etc). The processor is simple, so we call it a controller (like calling a small human a child), and it consists of two parts: the register file and the 'control sequencer'. Naturally, we've applied for patents on all this stuff.

## **REGISTER FILE**

The register file consists actually of 19 registers, each 16 bits wide. 16 of these are located in the 2114 RAM chips, and can be accessed by using the RA address lines. The 74LS374's 1J and 2J are the input register, and can be written by the CPU, which is how the CPU tells the controller to make a sound. The 74LS377's are the memory address register, and they tell the sound ROM the address for the particular sound sample valid in this time slot. The 74LS374's 5H and 6H are the sum register; this holds the incremented value that was supplied by any register on the previous controller state cycle.

These registers are controlled by a variety of signals. The input register can be selected by bringing IOE low to enable its output. Similarly the sum register can be selected by SOE. The memory address register can be programmed to capture data by bringing DLE low. Finally, any one of the 16 general purpose registers can be enabled to read by selecting it using RA0-RA3, or to write using RA0-RA3 and bringing WRP low. The only signal out of this mess is CARRY, which tells when the incrementer has reached a zero count.

### **CONTROL SEQUENCER**

The control sequencer runs the show for the register file. Each controller 'channel cycle' consists of 5 'state cycles'; there are 8 channel cycles in a sample period, one for each of the eight Drumulator output channels. Within each state cycle, the microcode PROM determines exactly what the register file will do depending on certain conditions. This is outlined in the timing diagram below, which you can use for reference if you want to be even more bewildered.

Counter 7D produces the 5 'state cycles', sending these to the microcode PROM. In addition, flip/flop 11D (both halves) performs as a 'request latch' to inform the control sequencer and microcode PROM that the CPU has written data to the input register. Finally, latch 12E will remember the state of the carry when the control sequencer last requested it be saved, and will tell the microcode PROM. Using these 5 bits of data (3 representing state, 1 for request, 1 for carry), the microcode PROM can perform any of the register functions mentioned above, and:

Reset the request latch

Enable the carry latch

Choose which of two sources (the current output channel or the CPU selected channel) will produce the general purpose register address

Enable the current output channel counter to be incremented.

The multiplexing between the two addresses is accomplished by the 74LS157. The counter 10D's most significant 3 bits represent the current channel, the least significant bit determines whether the 'size' or 'location' of this channel's general purpose registers are to be addressed. The same applies to the CPU-supplied channel number data stored in latch 13H.

The microcode is written to accomplish the following:

Check the size remaining to output for the current channel's sound. If it is zero, do nothing. Otherwise, decrement the size and re-write it for next time.

Determine the location in the sound ROM of the current channel's current sample. Output it to the sound ROM using the memory address generator. If the size was zero, do nothing. Otherwise, increment the address and re-write it for next time. If the Z-80 has written data into the input register, transfer it into the general purpose register specified by the Z-80. If not, do nothing. Otherwise reset the request latch.

Proceed to the next channel.

The result is a series of addresses which are output to the sound ROM, each representing the current sample of the current sound. If the sound is complete, the address will be the last address of the sound, whose data will cleverly be set to zero. Simultaneously appearing on the channel select lines CNLS0-CNLS2 is the number of the current channel (whose data point address appears on the MA0-MA15 lines).

The SHD line is synchronized by the clock circuitry to provide a sample/hold strobe signal that is synchronous with all this to aid in demultiplexing.

Relax, it's downhill from here on.

### **SOUND ROM**

The sound ROM is actually 4 93128 16K x 8 bit mask read only memories, giving a total of 64K bytes of sound data. This is not stored in a very logical location of particular sounds in particular ROMs, other than the fact that we used all of ROM 1E for the ride cymbal. The sockets are, however, compatible with the 27128 EPROM, and details on programming your own ROMs are available from E-mu. Note, however, that producing such ROMs will require several thousand dollars of specialized equipment, and that E-mu doesn't supply custom ROMs.

The sound ROM produces 8 bits of data representing a sound data point from the 16 bit memory address. The output of the sound ROM is thus the data for channel 0, then channel 1, and so on through 7, and then back to channel 0 again for a new sound data point, etc.

#### **MAIN DAC**

The main digital to analog converter is a 6072 companding DAC. This produces, from the stream of sound data, a multiplexed analog signal representing in sequence the current analog sample level for each of the 8 channels in sequence. These levels are still synchronous with the CNLS0-CNLS2 signals supplied by the control sequencer. The signal appears as a -5 to +5 signal at the output of 2D.

#### **LEVEL RAM**

The levels of the sounds are stored in 74LS670 dual-port memories 10H and 11H. This data was supplied by the Z-80 for each of the 8 channels before a sound was requested from the register file controller. During each channel cycle, the signals CNLS0-CNLS2 select one of the 8 read addresses from the level RAM, which produces a 4 bit level value. This is then interpreted into a logarithmic (dB) coding by the log PROM, and sent to the level DAC to be applied to the sound.

#### **LEVEL DAC**

The multiplexed analog signal from the main DAC is multiplied by the level DAC to produce a new multiplexed signal that represents each sound data point at its correct playback level. The level DAC is a CMOS multiplying DAC that produces as the output of 6C the signal at its input multiplied by the level numeric value presented at the digital inputs.

#### **SOUND DEMULTIPLEXER**

Now it's time to separate out the sounds for each of the eight output channels. This is done by the sound demultiplexer, which is really eight sample/holds. During each channel cycle, the CNLS0-CNLS2 inputs to the DMX-88 demultiplexer select the channel whose analog sample data has been produced on MUXIN. Then the SHSTB signal pulses high, charging the channel's hold capacitor to the sample voltage. This is done for all 8 channels in sequence. The 8 TL084 sections buffer the channel voltages.

#### **FIXED FILTERS**

Two of the channels—the ride and hi hat cymbals, can use as much high frequency energy as they can get, and hence are unfiltered. Four others, the snare / rim, bass, claps, and cowbell / clave, are filtered with five-pole 1dB ripple Chebyshev filters placed at appropriate frequencies to optimize the sound outputs. Note that these filters are somewhat sensitive to electrostatic coupling. This is where the high frequency buzz that can be heard at very high gain on the bass output enters the circuit.

#### **DYNAMIC FILTERS**

The remaining two channels for the toms use dynamic (voltage controlled) filtering to optimize the sound. The signal passes through an SSM2044 type voltage controlled filter. The control input of this filter has an AR type transient on it.

This AR transient is initiated by the Z-80 CPU, which sets the FILT line to zero for about 5 msec. This discharges the 10 uF capacitor through the 100 ohm resistor, creating the attack portion of the transient. When the CPU brings the FILT line high, the decay is produced by charging the 10 uF cap through the 30K resistor. The initial frequencies of the filters are adjustable, and are best set by bringing the filters into oscillation using the test points provided.

#### **MIXER**

The eight channel outputs are finally summed and level controlled to produce the infamous mix output.

**TIMING DIAGRAM**

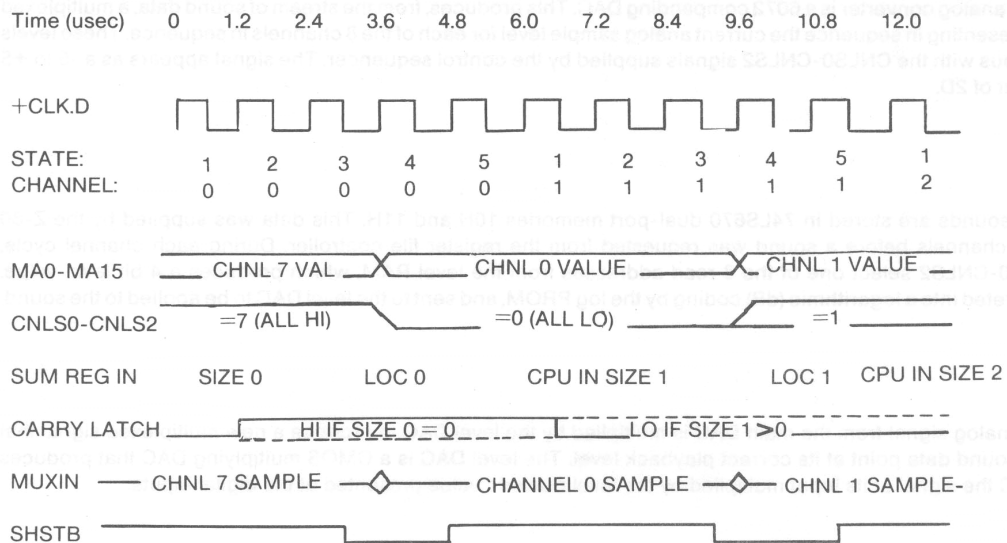

---

## **4 Drumulator Testing Procedure**

---

This section of the manual will describe how to test the Drumulator for proper functionality and give a few pointers on troubleshooting. Note that each step will have references to other sections of the manual for further information.

The Drumulator is a software-based instrument, and software never breaks. Therefore, testing will be restricted to the hardware, which is quite easy. As an example some of the blue buttons control six functions in software but only need to be pressed once to test the hardware. (easy huh?)

It has been our experience that most people do not read the manual thoroughly. Because of this, you will probably try to fix a machine that isn't broken. Because the customer might not know how to use the extensive capabilities of the machine, or know its limits, your knowledge of the features it has to offer and how to make them work is important.

If at any point, you determine that the machine must be opened up for troubleshooting, it is a good idea to record all of the customer's sequences to tape, if at all possible. It is too easy to accidentally destroy the non-volatile memory while working inside the machine. SEE SECTION ON CASSETTE INTERFACE OPERATION (4B & 4C).

1. Power up the unit and check that all the LEDs and display segments light for about four seconds. During this time the display will show four "8"s and four decimal points. This will tell you that all the Display segments and LEDs are functional. The display will then read "01 XX", XX being whatever segment is programmed into song 01. SEE SECTION ON DEFAULT SETTINGS (7A). If the unit gets this far, then the CPU and all of its memory are functioning correctly, which means you can skip to the next test. If you have a problem, however, stay tuned for more information. When a Drumulator has a problem (don't we all?), the display can help determine the nature of the problem. When it comes up "BAD" it means some data in the non-volatile memory has changed between the last time the unit was powered down and then powered up again. This can be caused by: battery failure, diode D3 being open, failure of the memory devices themselves, or a line voltage spike so large as to cause a memory write operation with bad data. When this happens the memory must be cleared by using the POOF routine.

### **POOF ROUTINE**

1. Turn machine off, then on
2. Select segment mode by pressing SONG/SEGMENT
3. Press and hold ERASE
4. While holding ERASE, press CASS, display will show flashing POOF
5. Still holding ERASE, press ENTER and listen for metronome beep

Now the machine is ready for tape or manual loading, so load some sequences into some segments. SEE SECTION 2F OF CONDENSED OWNER'S MANUAL FOR MANUAL LOADING OR CASSETTE INTERFACE FUNCTION SECTION 4B AND PRECEDING PARAGRAPH. After loading, power the unit down for about 3 minutes. Now power it back up and see if it comes up with a "bad" display. If it comes up okay try turning the machine on and off several times in rapid succession and see if that affects memory. If it does, then the decoupling capacitor on the +5 volt T03 regulator is suspect. It might be open or have a cold solder joint.

2. The next test is to insure all of the buttons can be recognized by the microprocessor. As mentioned previously the buttons need only be pressed once to test, even though they control up to six functions.



**BUTTON TEST - ALL TESTS ARE IN SEGMENT MODE**

MAKE SURE THE METRONOME LEVEL IS UP, POWER OFF, THEN BACK ON BEFORE STARTING

BUTTON TO PRESS	DISPLAY OR SOUND
RUN/STOP	IF SEGMENT IS EMPTY THE METRONOME WILL BEEP. IF NOT, THE SEQUENCER WILL START RUNNING. PRESS RUN/STOP 2ND TIME TO STOP SEQUENCE
PLAY A	BASS DRUM
PLAY B	SNARE DRUM
PLAY C	COWBELL
PLAY D	RIDE CYMBAL
PERC/DRUM	LED CHANGES FROM PERC TO DRUM MODE
BASS/CLAVE—press twice	RIGHT DISPLAY SHOWS 11
SNARE/COWBELL—twice	RIGHT DISPLAY SHOWS 22
CLAPS/RIM—twice	RIGHT DISPLAY SHOWS 33
HI-HAT/HI TOM—twice	RIGHT DISPLAY SHOWS 44
HI-HAT/MID TOM—press twice	RIGHT DISPLAY SHOWS 55
RIDE/LOW TOM—twice	RIGHT DISPLAY SHOWS 66
LOAD/MET/TRIG	DISPLAYS ME 4
PRESS ENTER AT THIS POINT TO CLEAR DISPLAY	
SAVE/MEM—hold down	DISPLAYS MM XX "XX" WILL BE A NUMBER INDICATING THE PERCENTAGE OF MEMORY REMAINING FOR SEQUENCER
LEVEL	DISPLAYS LE
ACCENT	DISPLAYS AC
TEMPO	DISPLAYS T XXX "XXX" IS A NUMBER BETWEEN 40 AND 240 TO INDICATE BEATS PER MINUTE. NOW MOVE THE SLIDER FROM THE TOP TO THE BOTTOM AND THE DISPLAY WILL CHANGE
SONG/SEGMENT	LED CHANGES FROM SONG TO SEGMENT MODE. LEAVE IN SEGMENT MODE
SELECT/AUTO CORRECT	DISPLAYS AU XX "XX" IS THE CURRENT AUTO CORRECT RESOLUTION. 4 THRU .32.
PRESS ENTER TO RETURN TO SEGMENT MODE	
REPEAT/SWING	DISPLAYS S6 50
PRESS ENTER TO RETURN TO SEGMENT MODE	
END/COPY	DISPLAYS CO _ _ WILL FLASH
PRESS ENTER	
</MEAS. LENGTH	DISPLAYS ML 4
PRESS ENTER TWICE	

BUTTON TO PRESS	DISPLAY OR SOUND	
>/SEG. LENGTH	DISPLAYS	SL 2
PRESS ENTER		
PRESS AND HOLD INSERT/ERASE	DISPLAYS	ER _ _ WILL FLASH
PRESS AND HOLD DELETE/RECORD THEN PRESS RUN/STOP	DISPLAYS	rc XX "XX" WILL BE THE NUMBER OF THE SEGMENT YOU ARE RECORDING INTO, ALSO THE METRO- NOME WILL BE RUNNING. IF SEGMENT HAS PREVIOUSLY BEEN RECORDED YOU WILL HEAR IT ALSO. PRESS RUN/ STOP TO STOP
ENTER	IF IT DOESN'T WORK YOU WOULD NOT HAVE GOTTEN THIS FAR	
CASSETTE	DISPLAYS	CASS PRESS AGAIN TO EXIT
PRESS AND HOLD EXTERNAL CLOCK	DISPLAYS	EC 01

### SOUND CHECK AND FILTER CALIBRATION PROCEDURE

To check all the sounds in the Drumulator, press one of the black play buttons and hold it. Next, by pressing the blue sound select buttons, six sounds in percussion mode and six sounds in drum mode are available. Listen to each sound separately and check for noise or distortion. If a sound doesn't work, verify that the button works, then see if the rest of the sounds play. Some of the sounds share output channels and always fail together. When one sound fails it is usually in the demultiplexer, sample/hold or filter circuits. If all sounds fail check their separate channel outputs first, as the mix out summing amplifier is suspect. Try the metronome if no sound comes out the mix out. If it works, the amplifier is okay so the problem is elsewhere. The signal into the demultiplexer is easy to see on the scope, so start here. SEE SCHEMATIC PAGE 11. If the signal doesn't get this far, check the level DAC and main sound DAC, and their buffer amplifiers. SEE SCHEMATIC PAGE 7. Also don't forget to check all the power supplies. If there is a signal at the demux input, the problem is in the demux or its sound channel select signals, or possibly it's a power supply problem.

We've had some problems with the 10 microfarad 25 volt blue tantalum capacitors shorting out and causing the plus or minus 15 volt regulators to shut themselves off. If one of the supplies is dead, turn off the power and take an ohmmeter and check the resistance from the +- 15 volts to ground. If it is very low, i.e. 0 to 10 ohms, then C60 for positive supply and C61 for the negative supply are the possible causes. In some cases they will smoke when they fail, which causes the owner of the machine to freak out. This is usually an easy fix, as all you do is replace the capacitor and clean up any mess. SEE SCHEMATIC PAGE 7 FOR C60 AND C61.

To calibrate the filters they must be resonated by jumpering the test point from left to right with a small alligator clip, then trimmed to 1.2 kilohertz. There are two filters to trim and they are located at the upper right hand corner of the PC board. The silkscreen indicates which test point to jumper and which trimpot to adjust.

### CASSETTE INTERFACE CHECK

To check the cassette interface you will need a cassette deck (a cheap portable one is fine), and a tape. There will need to be some sequences in the machine to record onto tape. The easiest way to do this is manually, as the Drumulator might not be able to load a tape at all. Select segment mode then select a segment, 11 thru 66 are valid segments, then press and hold RECORD and press RUN/STOP to start recording. Now play the black play buttons and it will be recorded into memory. Stop the recording by pressing RUN/STOP. Now there is something in memory to save to tape. Connect the tape deck from the Drumulator's CLK/CASS OUT to the tape deck record input. Press the CASS button and the display will show CASS, then start the tape recording and press SAVE. The LED above the CASS button will blink and the display will show SAVE. When it finishes, the display will return with CASS. Rewind the tape to the beginning and change the cable from the tape deck's input to the output and from the Drumulator's output to its input. Now press and hold SAVE, then press LOAD and the display will show CHEK which means the Drumulator will check the data that is on the tape to make sure that it is okay. Start the tape deck and watch the CASS LED start flashing to indicate the data is being read back. If the LED never flashes, the tape either isn't getting read or it didn't get recorded at all. Try listening to the tape for a sound like a turbocharged bumblebee at a good strong level. If the tape has data on it then the Drumulator can't read it back, so check the CASS/SYNC input comparator. SEE SCHEMATIC PAGE 13. If there is no data on the tape at all check the CASS/SYNC OUT. SEE SCHEMATIC PAGE 2. If you have a good Drumulator around it will be easier to set the tape deck up to work on it first, then try the machine in question.

#### **REAR PANEL JACK TEST**

The first jack to test is the mix out, so connect the Drumulator to an amplifier, turn the volume and metronome up about halfway and press any play button and you should hear BOOM, SIZZLE ETC. Now that that's out of the way, find an empty segment or make one by erasing it.

#### **SEGMENT ERASE PROCEDURE**

1. SELECT SEGMENT MODE
2. PRESS AND HOLD ERASE
3. WHILE HOLDING ERASE SELECT SEGMENT TO BE ERASED 11 THRU 66
4. WITH ERASE STILL PRESSED, PRESS ENTER AND METRONOME WILL BEEP TO INDICATE THE SEGMENT IS NOW EMPTY.

Now enter record mode by pressing and holding record then press RUN/STOP. You will now hear the metronome running. Turn the metronome and mix level pots through their full range and listen for smooth attenuation with no clicks or pops. Now move the cable from the mix out to the metronome out (a different cable or adapter will be needed) and listen for the metronome. Press RUN/STOP to stop sequencer.

The next test will be the separate sound channel outputs, so move the cable from the metronome to the bass drum output and press play switch A, and you will hear the bass drum. If you don't get the bass drum sound the switch will need to be assigned to it. To do this press play switch A and hold it, then press the blue select button for the sound you want and it will be assigned to the play switch. To test the rest of the jacks, plug the cable into them and play the appropriate sound and listen for noise distortion etc. If a separate channel output doesn't work but the mix out does, it is either the 1 K ohm resistor or the jack is bad.

The external RUN/STOP jack is tested by plugging a momentary footswitch into it, then pressing the footswitch and listening for the sequencer to start running (unless the segment is blank—if this is the case then all you will get is a beep from the metronome). Next plug the footswitch into the repeat jack and select SONG MODE with the SEGMENT/SONG button. Now press and hold the footswitch and the display will read So 1 which is song one. Release the footswitch and press and hold again. Now the display will show So 2. Every time the switch is pressed the song will advance up to 8, at which point it starts over at 1.

It's time for the fun test now, so get a cable with a RCA jack on one end and a ¼ inch phone on the other and plug the RCA into the CLK/CASS OUT and the ¼ end into the GATE A jack. Select segment mode with any segment and press RUN/STOP and listen to the mix out. Sounds good eh? What you are hearing is the sound presently assigned to PLAY A being triggered by the sequencer clock. If you now press TEMPO and change the setting by moving the slider, the speed triggering will change from slow to frantic. Try the other GATE jacks to see if they work. If you want to have a little fun, try recording some sequences like this for effects.

---

## **5 Drumulator Debug Package**

---

The Drumulator debug package is intended for both production and field testing / debugging of Drumulator hardware. It is not intended as a final Q.A. functional test system, as this must be accomplished with the current production release of Drumulator software and a separate procedure will be outlined for final testing. Rather, the debug package is designed to isolate specific problems within a Drumulator and assist the technician in correcting them.

The Drumulator debug package consists of a set of PROMs; a program PROM and a sound PROM, and a manual describing the functional use of the package.

The debug program PROM will perform various tests, such as memory read/write, LED on/off, pushbutton integrity, etc. Several of the debug programs will utilize the debug sound PROM, which contain useful sound data like sine waves, ramp waves, and square waves of known frequency and duration.

The purpose of this document is to describe the internal design and methodology used in the debug package. Often it is quite useful for the technician working with a debug package to know the steps that a program is going through, in order to understand how it is failing. This document is provided so that the technician need not pore over the debug code to determine its operation. Though in rare instances that, too, may become necessary.

### **DEBUG DESIGN METHODOLOGY**

In general, the design methodology used in the debug package is one of finite containment. That is to say, the programmer strives to use only those elements of the hardware system that are essential in the test at hand. Thus, if you are testing the LEDs, the program should not also use the CTC; as a failure in the CTC might lead the technician into thinking that there was something wrong with the LEDs. So, in general, only the Z-80 processor and the program PROM will be used where possible.

In addition, if the memory system is dysfunctional then the debug software might not run at all, and would be pretty worthless; so wherever possible the debug software will not use the read/write memory. Any section that must use the read/write memory will be so documented in this manual.

The following will be a blow by blow description of each debug test, referenced by the test number.

### **DEBUG SET-UP PROCEDURE**

In order to use the debug package you must replace I.C.s 12K and 1E as follows:

- 12K - Debug Program Prom
- 1E - Debug Sound Prom A

After carefully inserting these two proms, the debug package is ready to use.

#### **Debug Initialization and Power-Up**

At power on time the Z-80 performs the following steps as initialization:

- 0) The Z-80 automatically disables interrupts and begins execution at address zero.
- 1) Clears the microcontroller registers, so that it doesn't make any sounds.
- 2) Clears all the CTC registers and disables them.
- 3) The debug package signs-on with a display message of "-- 00" (Test Number 00)
- 4) The pushbutton array is scanned for a key pressed. Only the Play1 and Run/Stop keys are recognized. The Play1 is used to select a test to be executed and the Run/Stop key is used to begin execution of a selected test. Each time the Play1 key is pressed the display will increment through the valid test numbers.

#### **Test 0 - All Lamps On**

Executing Test 0 will cause all lamps on the Drumulator to light, giving a quick go/no go check of all the LEDs.

- 0) Once entered, the test will continuously select all lamps and turn them on. It will remain in this loop until the Run/Stop key is pressed again, which will return back to command mode.

#### **Test 1 - Stepped LED Segment and Lamp Test**

This test is used to step each of the lamp segments on and off to check for opens and/or shorts between lamp segments in the display. Once entered, this test will light each lamp segment individually, advancing one segment with each press of the Play1 key.

- 0) Test begins with all lamps off, and the program will enter a loop waiting for the Play1 key to be pressed; each time the Play1 key is pressed a new segment will light. If at any time two segments light at once, they are most likely shorted together.
- 1) If at any time the Run/Stop key is pressed, the test will terminate and return to command mode.

#### **Test 2 - Stepped Pushbutton Test**

This test is used to check each pushbutton for valid operation. As each pushbutton is pressed, the number code for that button will appear on the display; i.e. "10".

Once Test #2 is selected and executed, the processor will scan all the keys for any key pressed. When a key is pressed, the display will indicate a number code for the key pressed. The processor will continue to scan that key until the user presses the Play1 key, which will cause the processor to resume scanning all keys again.

When Test #2 is initially executed the display will go blank, until a key is pressed. If the display does not go blank, and comes up with a number code initially; this indicates that the coded key has a short on its line, causing the processor to think that the key is always being pressed.

Key Codes:

The number codes for the keys are derived very simply, starting from the Run/Stop key, the keys are numbered from left to right, and bottom to top, so:

Run/Stop = 0  
Play1 = 1  
Play2 = 2  
Play3 = 3  
Play4 = 4  
Level = 5  
Per/Drum = 6  
etc.

- 0) The processor will scan the pushbutton array for any key pressed, and will indicate the code for the key pressed on the display.
- 1) If at any time the run/stop key is pressed, the test will terminate and return to the command mode.

#### **Test 3 - Click test**

The click test will verify that the click output is correct, by outputting a 1kHz square wave output. The check may be audible or examined with the oscilloscope.

- 0) The processor goes into a loop, triggering the click output.
- 1) Pressing the Run/Stop key will abort to the command mode.

#### **Test 4 - Scratchpad Memory Read/Write test**

The scratchpad memory read/write test performs a comprehensive pattern test on the two 2114 static memories (14J and 15J). The result of the test is indicated on the seven segment LED display. If the test completes with no errors it will display the message "Good". If errors are detected, the test will display the address of the error in hexadecimal. When an error is detected the user may press the Play1 key once, which will display both the expected data and the erroneous data on the display. The expected data will be on the left two segments and the actual data read will be on the right two segments.

The test program itself is fairly involved, and is implemented as follows:

- 0) The processor writes an alternating pattern in memory to begin, 00's are written at all even-numbered addresses and FF's are written at all odd-numbered addresses. The writing proceeds from low address up to high address.
- 1) Tests are made for correct data at alternating even and odd addresses; as the current data is tested, new data of a rippling bit pattern is also written into memory.
- 2) Once the rippling bit pattern has rippled through all eight data bits of every memory address, new data of all zero's is now written to memory; this time from the top of memory down to the low addresses.
- 3) Tests are made for correct data, this time from the high addresses down to the low addresses.
- 4) If no errors are found, the display will indicate "Good", otherwise the offending memory address is displayed.
- 5) Pressing the Run/Stop key will terminate the test at any time desired.

#### **Test 5 - Nonvolatile Memory Read/Write Pattern Test**

This test is essentially the same as test #4, except that the nonvolatile memory is tested in place of the scratchpad memory.

All steps and instructions of the above test apply equally to this test.

#### **Test 6 - Nonvolatile Memory Address Pattern Setup**

This test is used in conjunction with test #8, to test the ability of the nonvolatile memory to remember data once the Drumulator has been turned off. Please note that for this test to have any meaning the on-board battery must be installed in the Drumulator. Test #6 and Test #7 both establish known data in the nonvolatile memory, which Test #8 will look for once the Drumulator is switched back on. The overall scheme is like this:

- Step 1 - Check to see that the lithium battery is installed in the Drumulator board.
- Step 2 - Select test #6 and run it. The display will come up with the message "OFF", indicating that you should now switch the Drumulator power off.
- Step 3 - Wait a good long while (overnight preferably).
- Step 4 - Switch on the Drumulator and select Test #8.
- Step 5 - Run Test #8, and if the data that Test #6 left in memory is still intact, it will display the message "Good".
- Step 6 - Repeat the above procedure, except use Test #7 in place of Test #6. This will use a different pattern in the memory, and display the message "OFF-", the dash indicates that the data is the inverse of that used in Test #6.

Test #6 operates internally in the following manner:

- 0) The processor writes a pattern into the nonvolatile memory; the data pattern is straightforward, using the low byte of the memory address as the data written.
- 1) Immediately after writing each byte of data the processor reads it again to verify that it got to the nonvolatile memory.
- 2) If no errors are encountered, the test will complete with the message "OFF". If an error is encountered, the test will indicate the address of the error on the display. As with the other memory tests, after the offending address is displayed the user may press the Play1 key to examine the faulty data.

#### **Test #7 - Nonvolatile Memory Complement Address Pattern Setup**

Test #7 functions exactly as test #6 above, with the exception that the data used is the inverse of that in Test #6.

#### **Test #8 - Nonvolatile Memory Data Retention Test**

This test is used to verify that the data placed in nonvolatile memory by either Test #6 or Test #7 has remained in the memory unchanged after turning the Drumulator on and off again. In order for Test #8 to make any sense, the user must have a lithium battery in the Drumulator, and have previously executed either Test #6 or Test #7 to establish a pattern in the memory. Test #8 functions like all the other memory tests in its response. If no errors are detected the display will read "Good", and if an error is found the address of the error will be displayed.

The internal design of Test #8 is as follows:

- 0) The processor reads the first location of nonvolatile memory to be determined if the normal pattern (left by Test #6), or the complemented pattern (left by Test #7) are present in memory. If neither pattern is present it signifies an error immediately.
- 1) The processor then continues on through memory to check the pattern, until an error is found or all of the memory is checked.

#### **Test #9 - Nonvolatile Memory Erase Function**

In the course of testing, it is sometimes useful to erase any previous test patterns left in the nonvolatile memory. Test #9 is provided for that purpose. After executing Test #9, the display will indicate "PooF" and light all the discrete LEDs on the board to indicate that anything that was in your nonvolatile memory has been blown away. The test simply clears the memory to all zeros.

#### **Test #10 - Sound Loop Tests**

Test #10 is used in conjunction with the DEBUG SOUND PROM A, which replaces the production DRUMULATOR SOUND ROM A, in I.C. location 1E. This test is used to generate test waveforms such as sine waves, square waves and triangle waves in order to test the output sections of the Drumulator. In addition, since several frequencies of each waveform are available, these waveforms can be used to test the filter frequencies of the various output filters. Since the DEBUG SOUND PROM replaces DRUMULATOR SOUND ROM A, the RIDE drum sound is no longer available, but all the other normal drum sounds remain and can be played through any of the eight output channels.

To execute test #10, advance the test selection until the display reads "-- 10", and press the run/stop key to execute.

- 1) Once entered, test #10 will display the message "S. 00". This is telling you that sound #0 is selected, by pressing play1 key you can advance the sound number through all twenty possible sounds. If you advance beyond the twenty sounds the sound selection will reset back to zero. When you have reached the desired sound number, pressing the run/stop key will select that sound number and move you along to the channel selection.
- 2) Once the sound number has been selected, the display will read as "C. 00", which is asking you for a channel selection. This works the same way as the sound number selection; to advance the channel number, press the play1 key and to select the channel number press the run/stop key. There are eight possible channels and advancing the channel selection beyond the eighth channel will put you back to channel zero. Once you select the channel number (by pressing the run/stop key) the sound will begin to play from the selected output channel.
- 3) The selected sound will play continuously from the selected channel, until the run/stop key is pressed again. The program will then exit back to test #0 ("-- 00").

#### **Internal Structure of the Sound Loop Test**

- 1) The sound test internally consists of two separate sections, the sound/channel selection section, and the actual sound generation loop.
- 2) The sound/channel selection uses the LED array and the pushbutton array in the same way all the previous tests do, scanning out the LED pattern while reading the pushbutton busses to look for a key pressed.
- 3) The sound generation loop uses the Z-80 processor to trigger the microcontroller logic in time with the waveform generated. The Z-80 processor sits in tight loop counting out time, to determine when the microcontroller needs to be retriggered. In general, one complete wave will be formed by the microcontroller and the Z-80 will then retrigger the microcontroller to form the next wave and so on.

- 4) While the Z-80 is counting out time, it is also reading the run/stop key to test for a stop request. Pressing the run/stop key will terminate with the utmost prejudice, and return you to test #00.

**Sound Numbers and Their Correspondance to Reality**

<u>Sound Number</u>	<u>Sound Type</u>
0	81.3 Hz Sine Wave
1	162.7 Hz Sine Wave
2	325.5 Hz Sine Wave
3	651.0 Hz Sine Wave
4	1302.0 Hz Sine Wave
5	2604.0 Hz Sine Wave
6	5208.0 Hz Square Wave
7	10416.5 Hz Square Wave
8	2604.0 Hz Sine Wave (Extended Length)
9	Mid Tom
10	Lo Tom
11	Open High Hat
12	Closed Hi Hat
13	Snare
14	Clave
15	Hi Tom
16	Bass
17	Rimshot
18	Cowbell
19	The Clap

**Test #11 - Output Filter Tests (Open/Close)**

The output filter tests the Q-control inputs of the output filter for channel 0 and channel 1. Both filter control inputs are triggered each time that the play1 key is pressed. The filters are held open for 5ms and then closed for 5ms. The test then waits for a key to be pressed, play1 will trigger the filters again and the run/stop key will terminate the test.

**Test #12 - Counter/Timer Read/Write Tests**

Test #12 is used to test the Z-80 CTC chip to verify that all four counter channels read and write correctly. All possible values (0-255) are written into the time constant registers of the CTC and read to verify the result.

- 1) The test begins by turning off the LEDs and disabling interrupts.
- 2) Then data is written to each of the counter channels in reverse order, CTC 3, CTC 2, CTC 1, CTC 0.
- 3) Then data is read from each of the counter channels in ascending order, CTC 0, CTC 1, CTC 2, CTC 3.
- 4) This continues until all values have been written to each channel.
- 5) If at any point an error is found the display will indicate the channel at fault as "CTC 0", etc.

**Test #13 - Counter Timer Interrupt Tests**

Test #13 is used to verify the operation of all counter channels and their ability to interrupt the processor. Timer mode is used in this test, when the counter channel counts down to zero it interrupts the Z-80. One channel is tested at a time, starting with channel zero and ending with channel three.

- 1) All counter channels are disabled and the CTC interrupt vector is established. The LED display is written to a "0" to indicate that CTC0 is about to be tested.
- 2) CTC0 is set up in timer mode, and interrupts are enabled. The processor then halts, to await an interrupt.
- 3) The interrupt service routine for CTC0 puts up a "1" on the LED display to indicate the CTC1 is the next one to test.



- 4) CTC1 is set up in timer mode, and interrupts are enabled. The processor then halts, to await an interrupt.
- 5) The interrupt service routine for CTC1 puts up a "2" on the LED display to indicate that CTC2 is the next to test.
- 6) CTC2 is set up in timer mode, and interrupts are enabled. The processor then halts, to await an interrupt.
- 7) The interrupt service routine for CTC2 puts up a "3" on the LED display to indicate that CTC3 is the next to test.
- 8) CTC3 is set up in timer mode, and interrupts are enabled. The processor then halts, to await an interrupt.
- 9) The interrupt service routine for CTC3 clears the LED display and returns to the main test section.
- 10) The Main test section then displays the message "Good", indicating that all tests passed.

\*\*\*\*\* If at any point a CTC channel fails to interrupt, the processor will be halted and the offending channel number will remain on the display. The only way out at this point is to cycle the power off and on again.

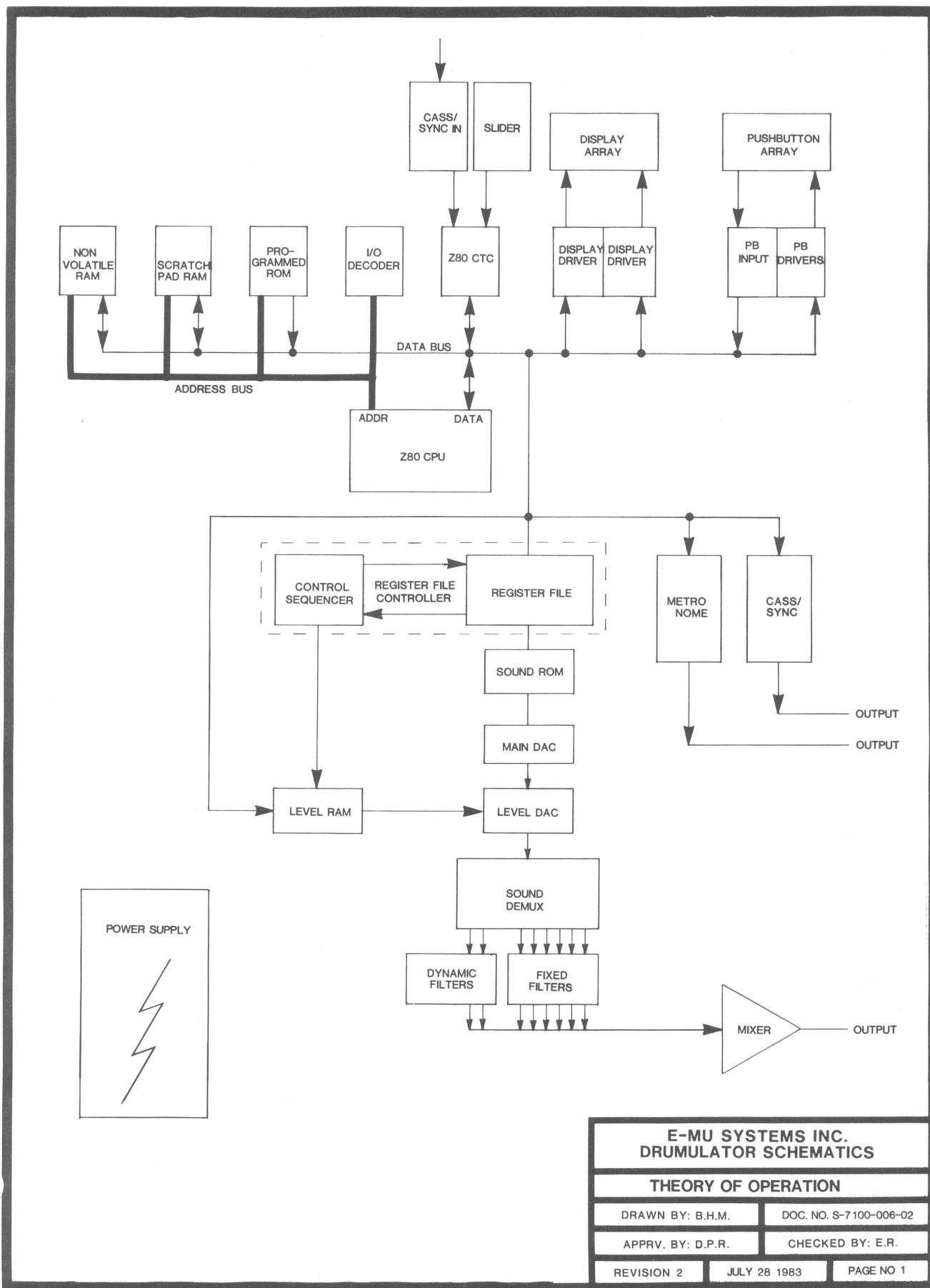

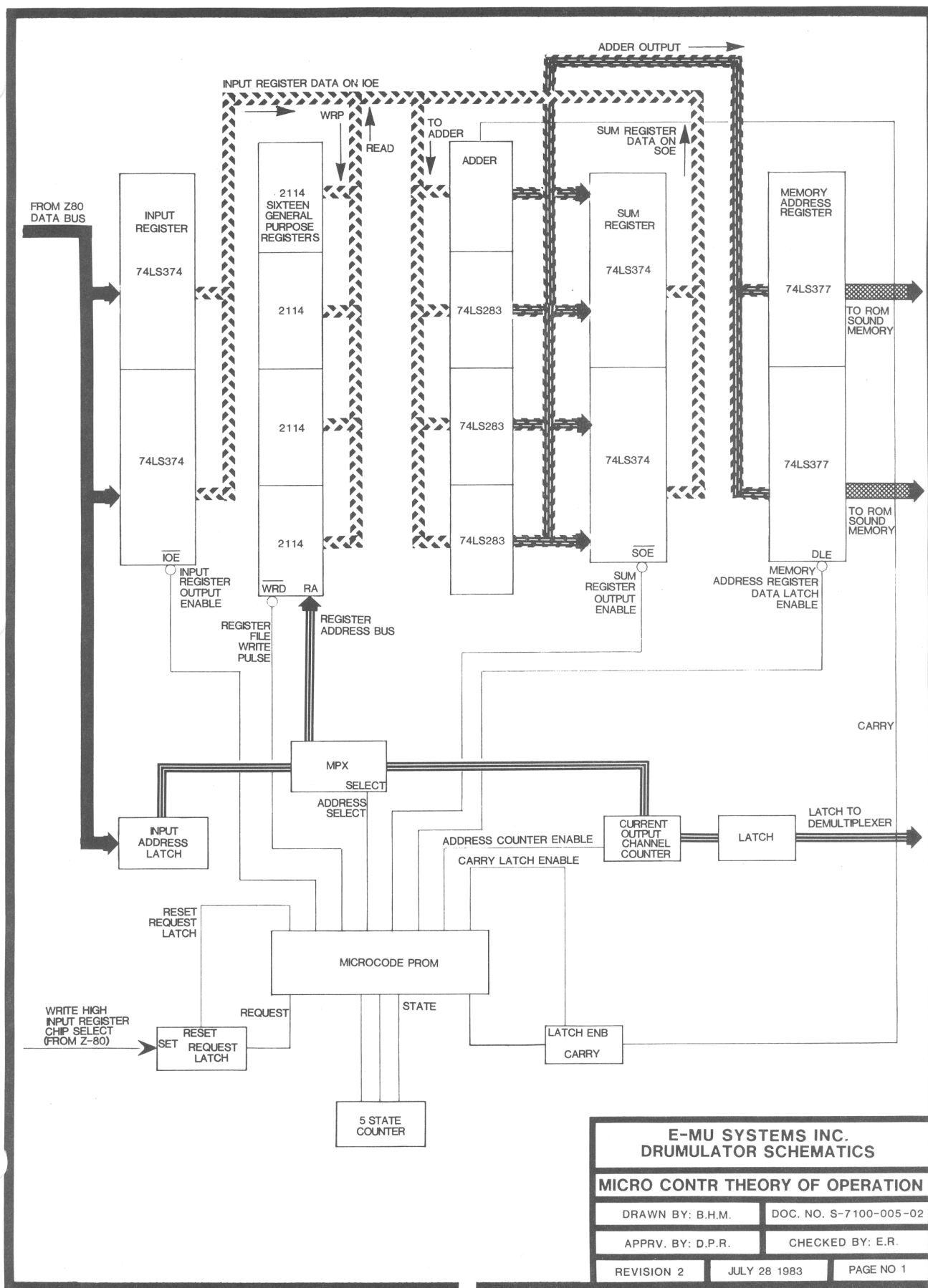

<b>E-MU SYSTEMS INC. DRUMULATOR SCHEMATICS</b>		
<b>MICRO CONTR THEORY OF OPERATION</b>		
DRAWN BY: B.H.M.	DOC. NO. S-7100-005-02	
APPRV. BY: D.P.R.	CHECKED BY: E.R.	
REVISION 2	JULY 28 1983	PAGE NO 1

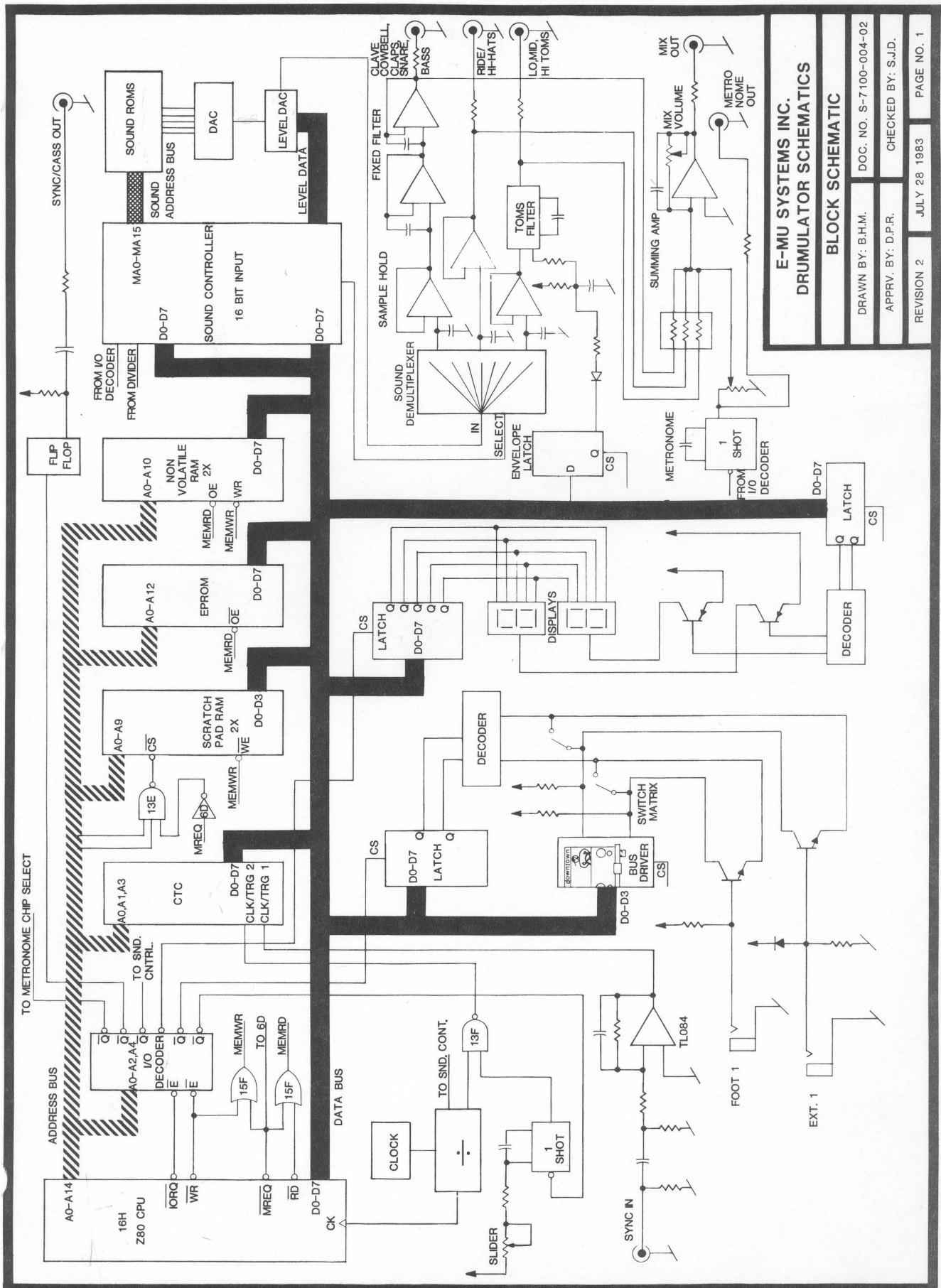

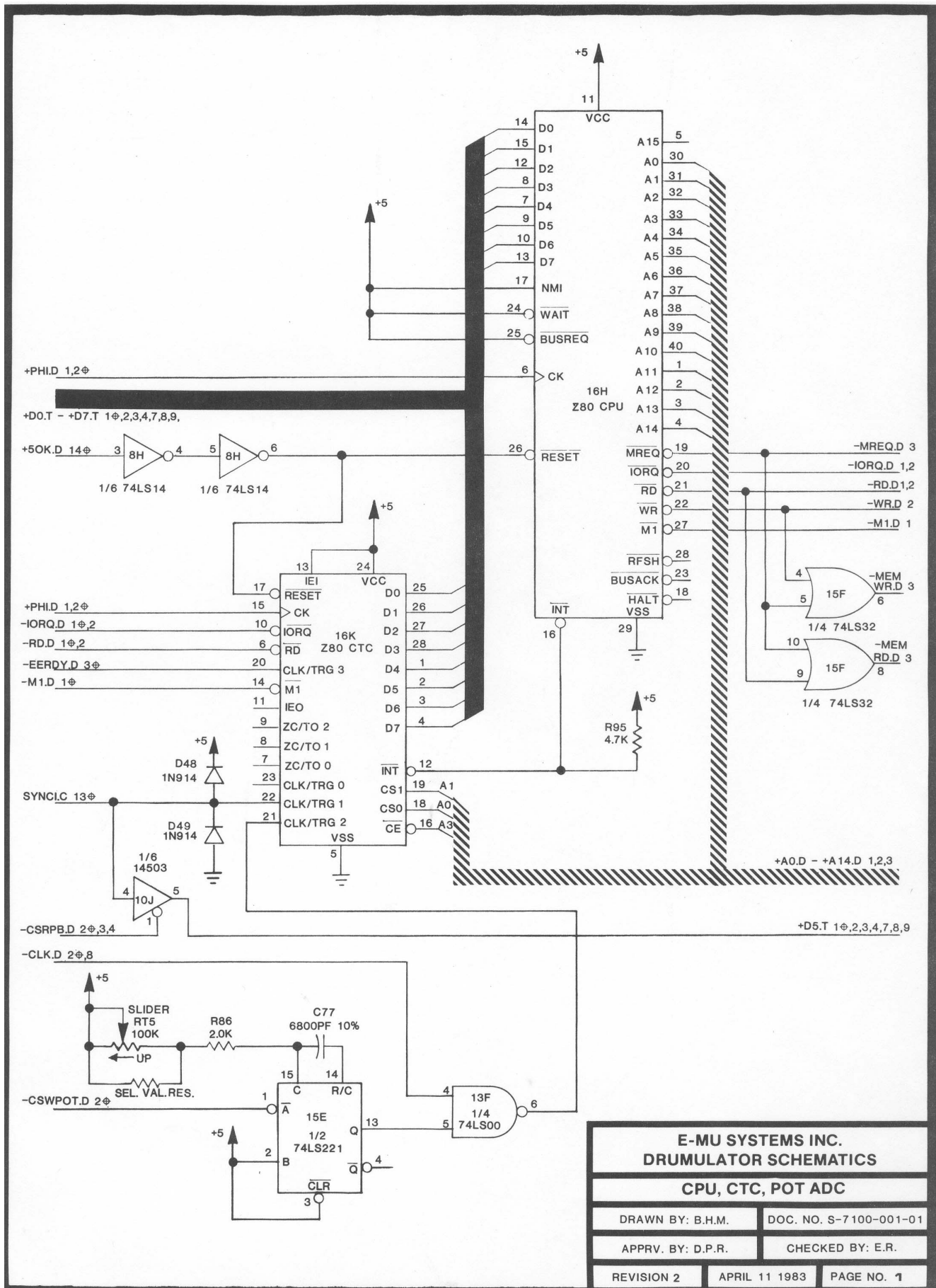

<b>E-MU SYSTEMS INC.</b>	
<b>DRUMULATOR SCHEMATICS</b>	
<b>CPU, CTC, POT ADC</b>	
DRAWN BY: B.H.M.	DOC. NO. S-7100-001-01
APPRV. BY: D.P.R.	CHECKED BY: E.R.
REVISION 2	PAGE NO. 1

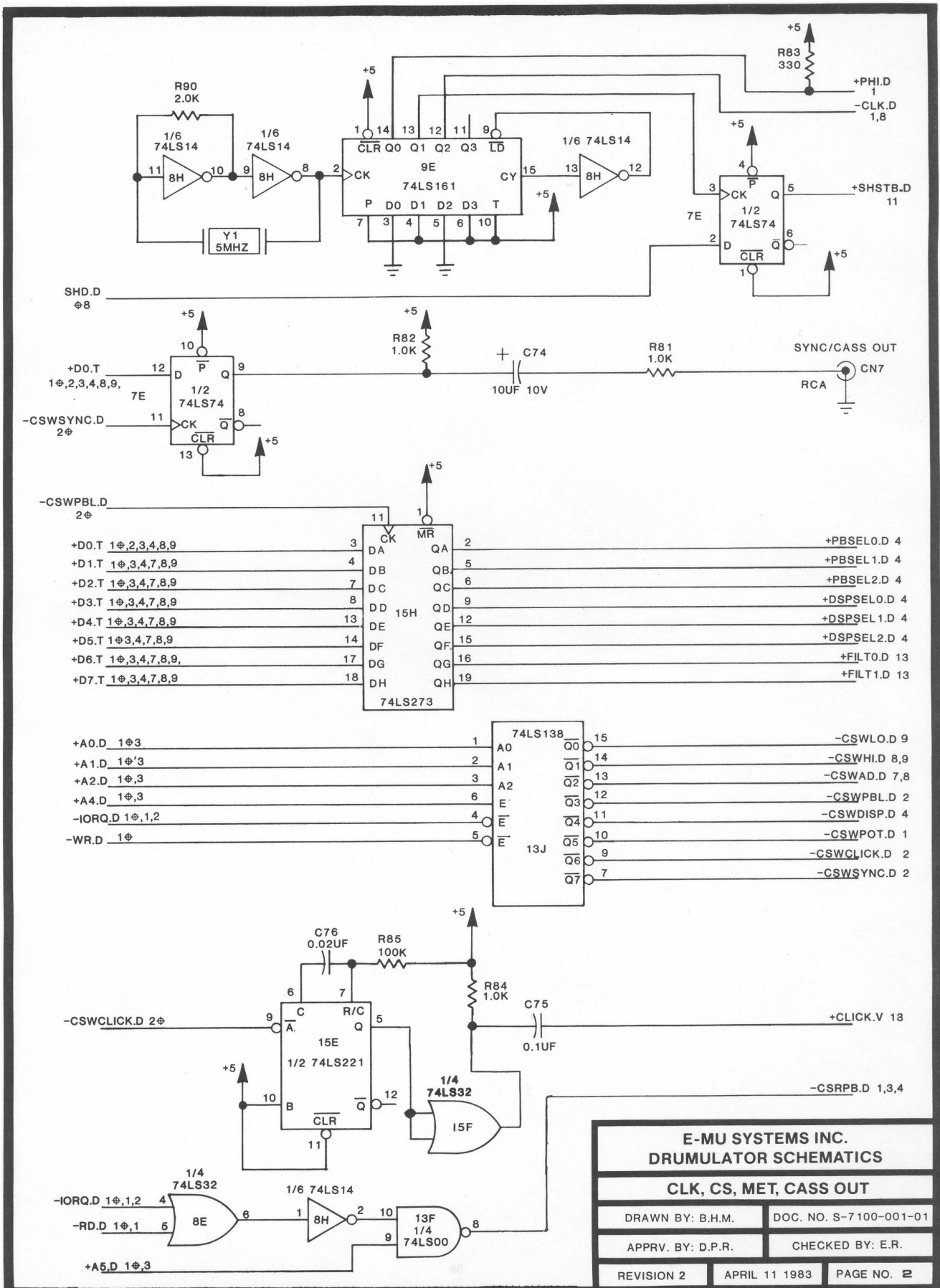

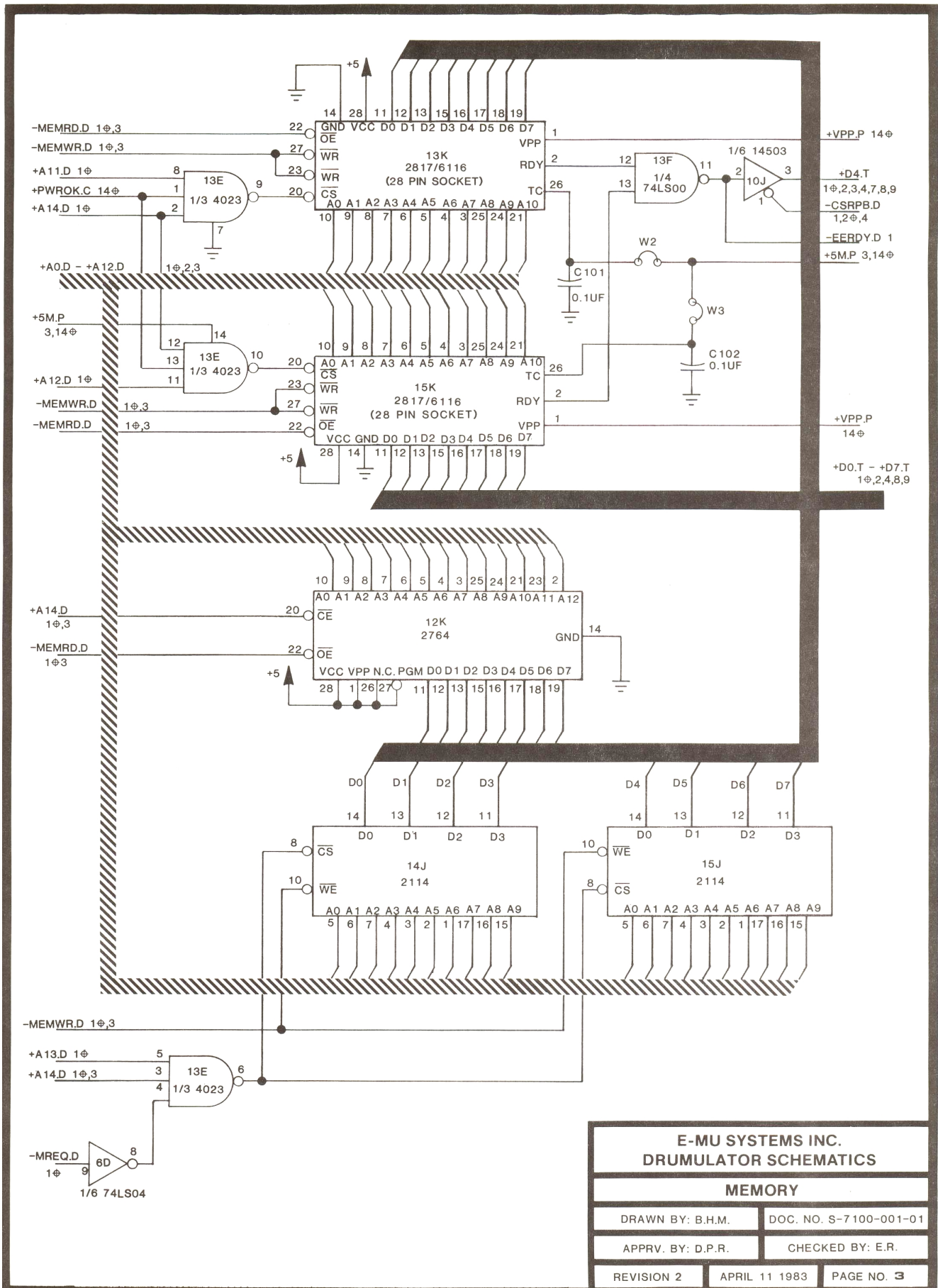

<b>E-MU SYSTEMS INC. DRUMULATOR SCHEMATICS</b>	
<b>MEMORY</b>	
DRAWN BY: B.H.M.	DOC. NO. S-7100-001-01
APPRV. BY: D.P.R.	CHECKED BY: E.R.
REVISION 2	PAGE NO. 3

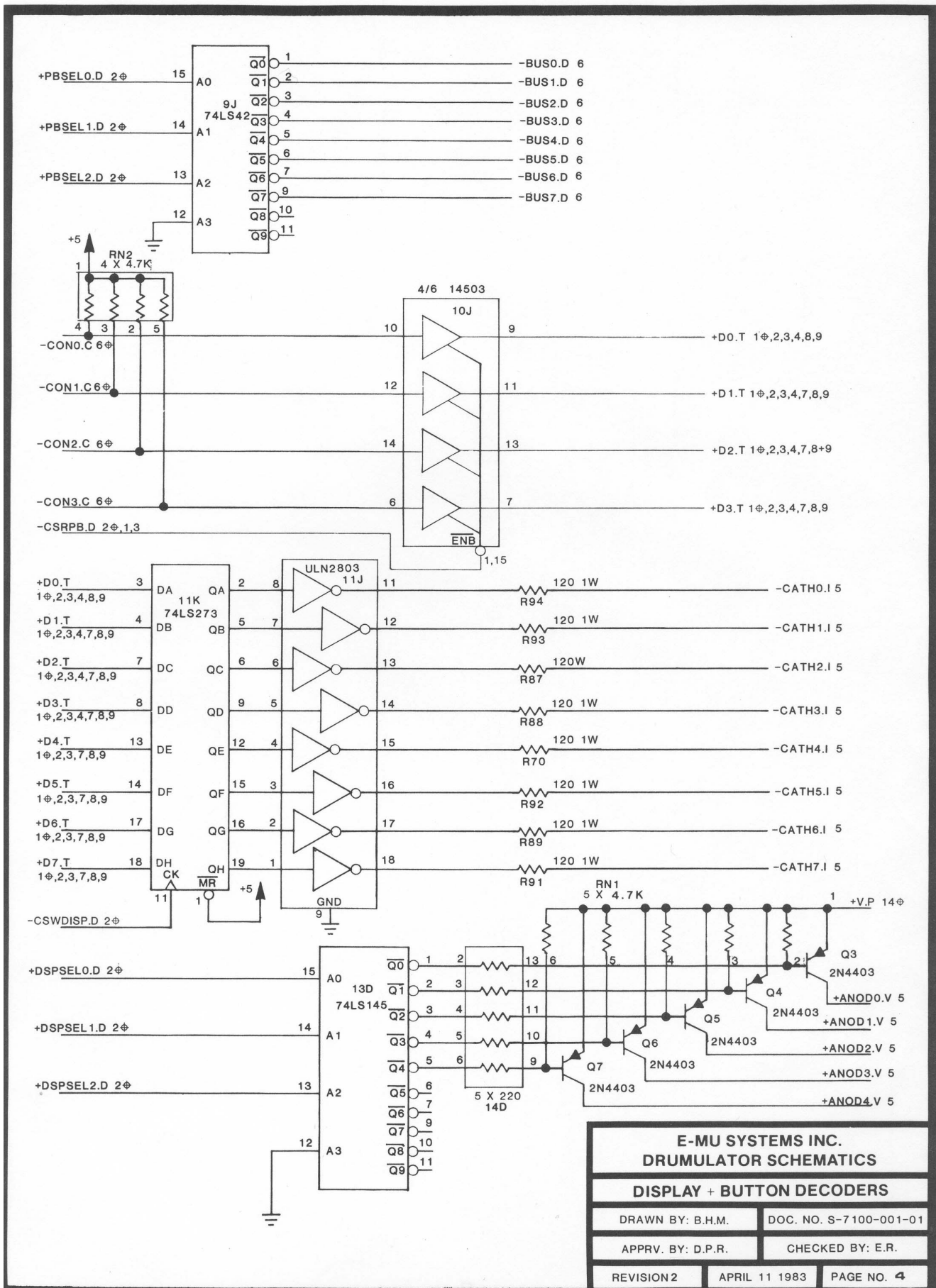



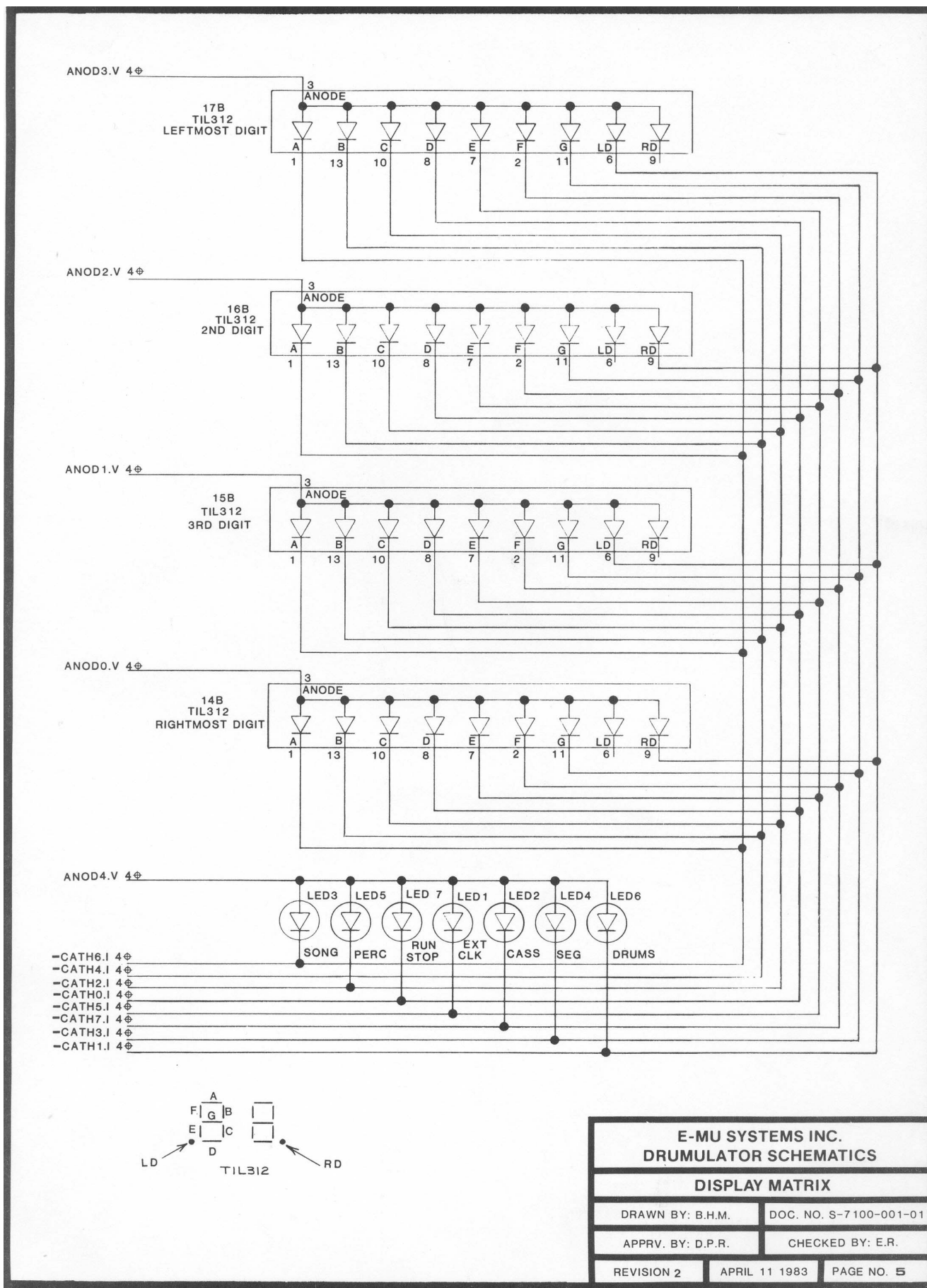

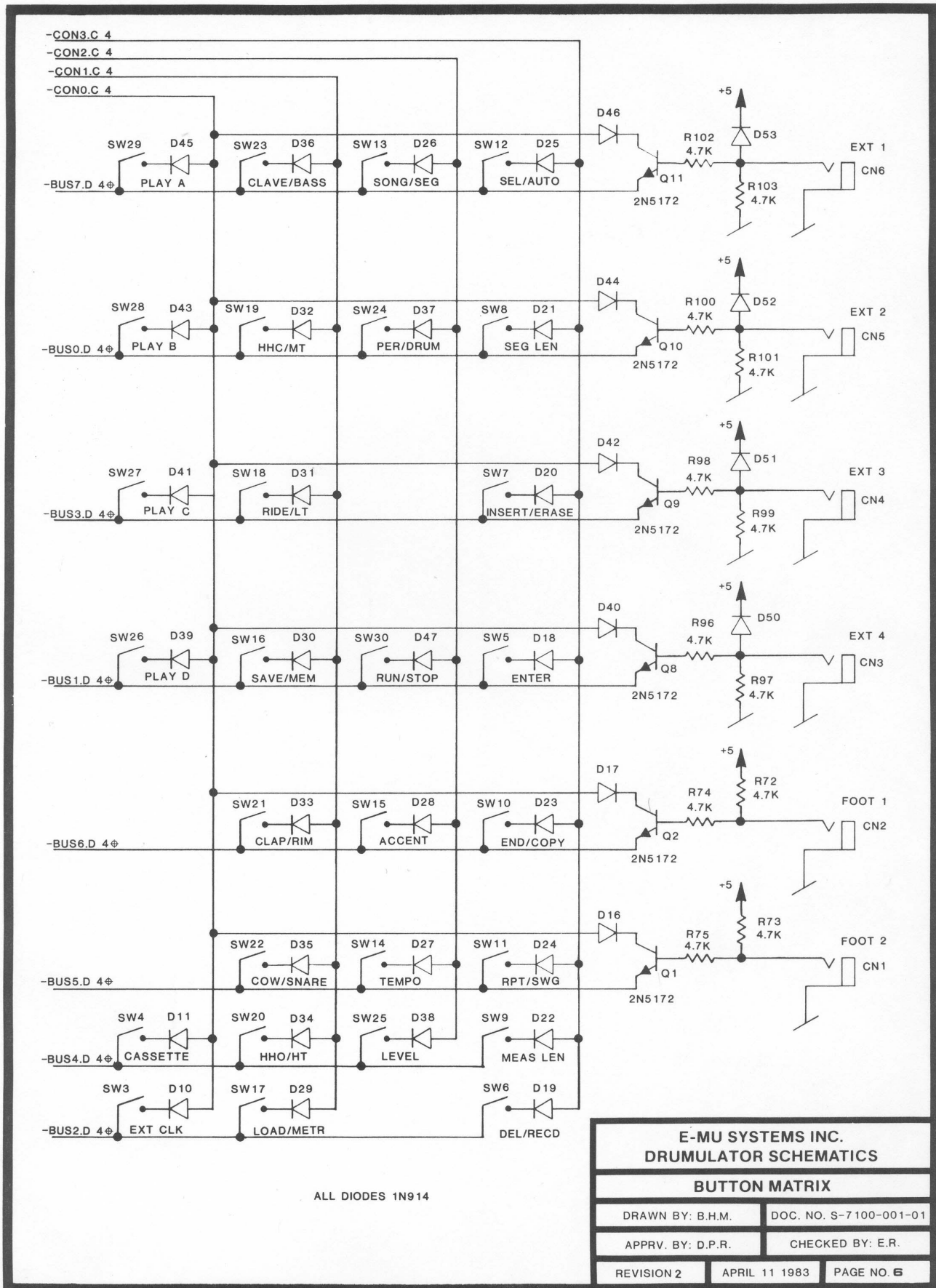

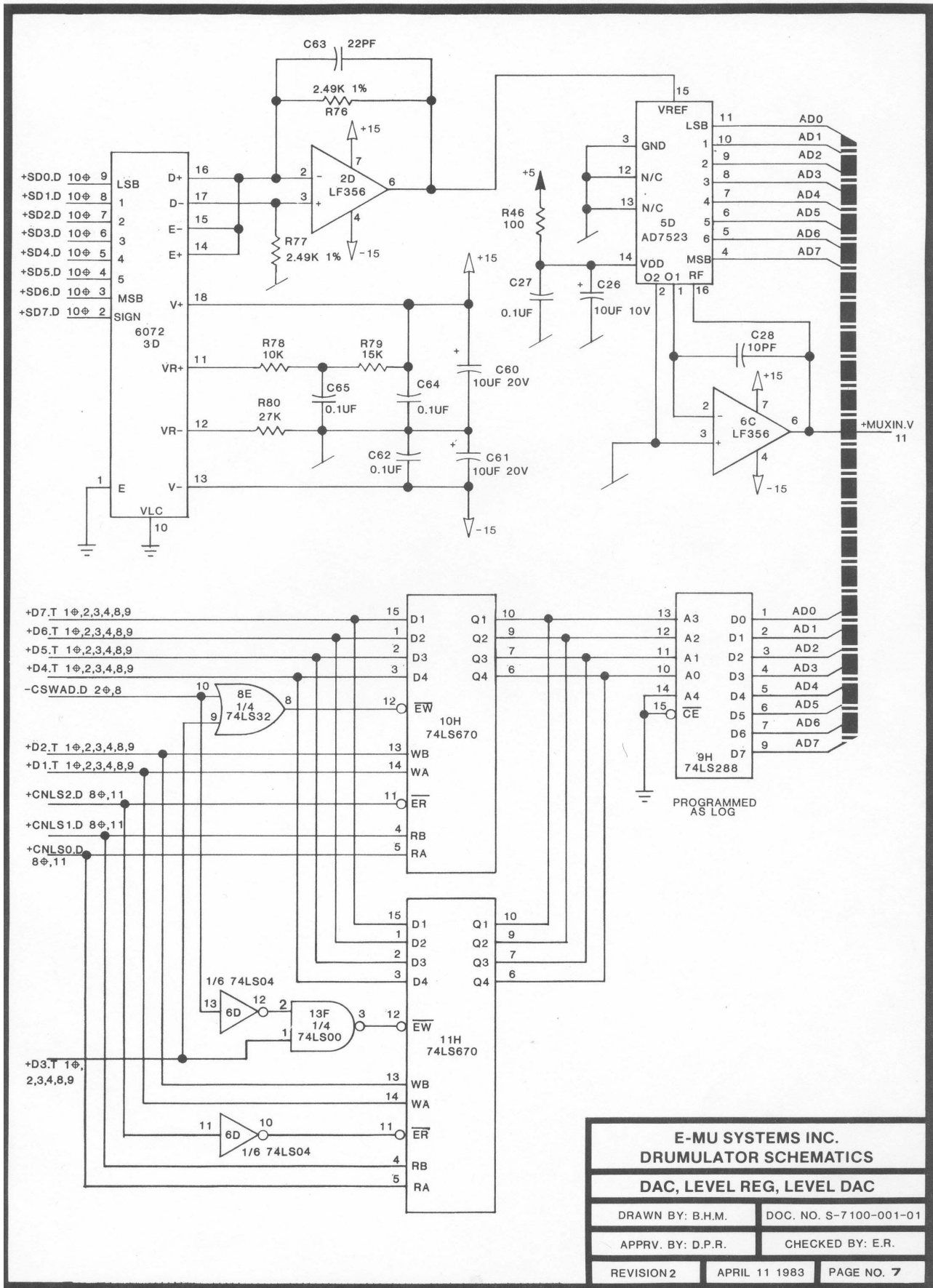

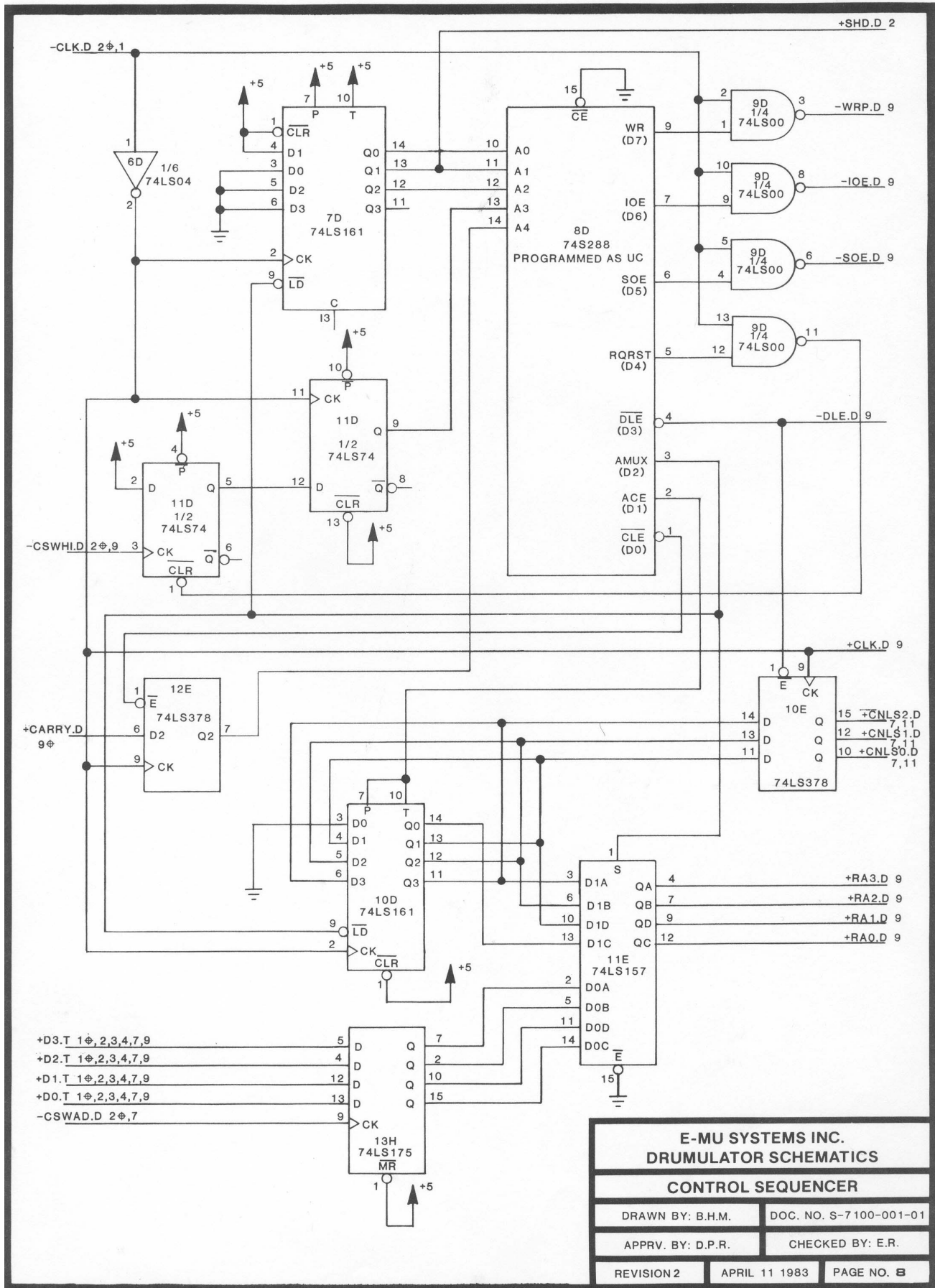

<b>E-MU SYSTEMS INC.</b>	
<b>DRUMULATOR SCHEMATICS</b>	
<b>CONTROL SEQUENCER</b>	
DRAWN BY: B.H.M.	DOC. NO. S-7100-001-01
APPRV. BY: D.P.R.	CHECKED BY: E.R.
REVISION 2	APRIL 11 1983 PAGE NO. 8

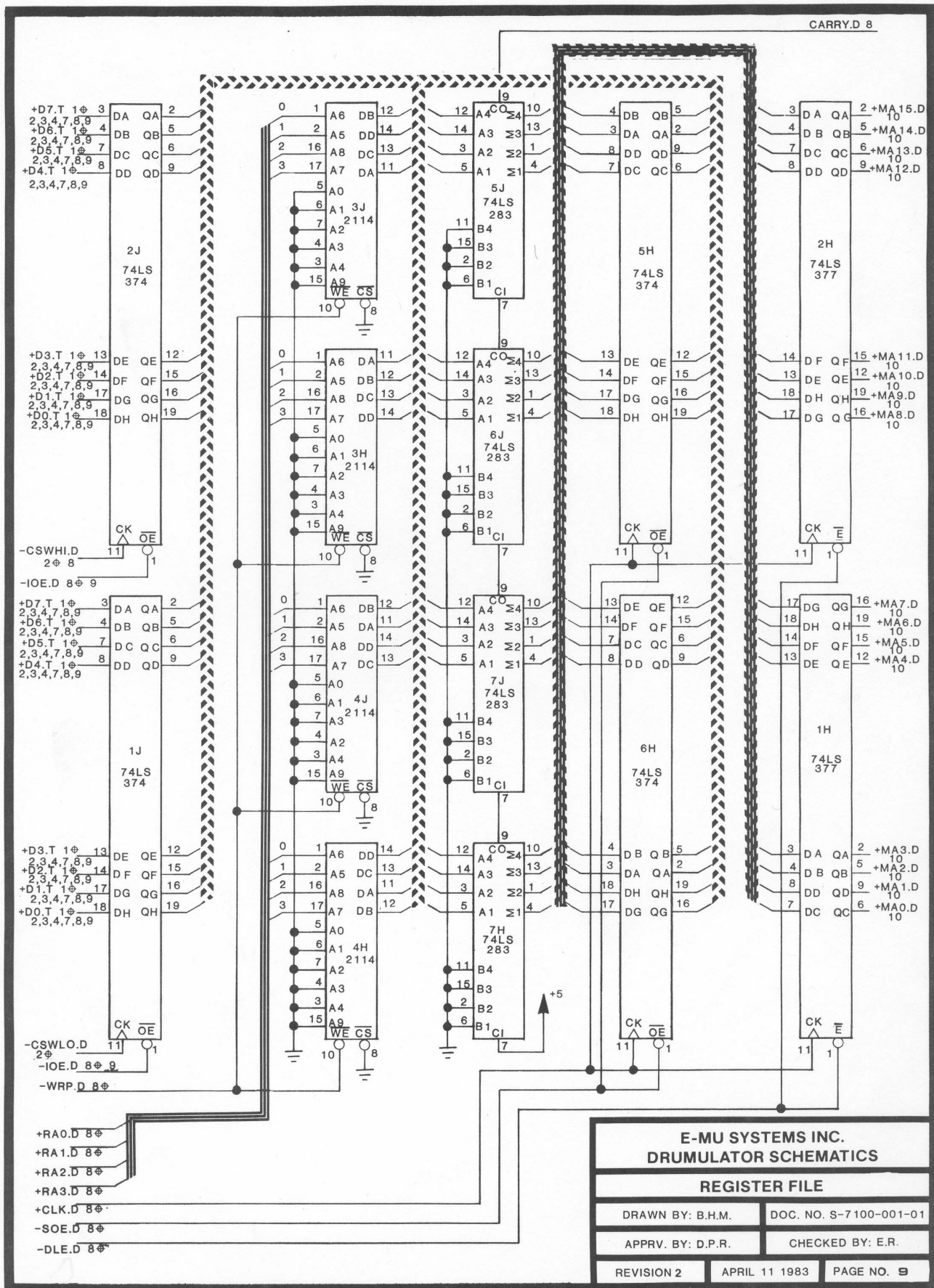

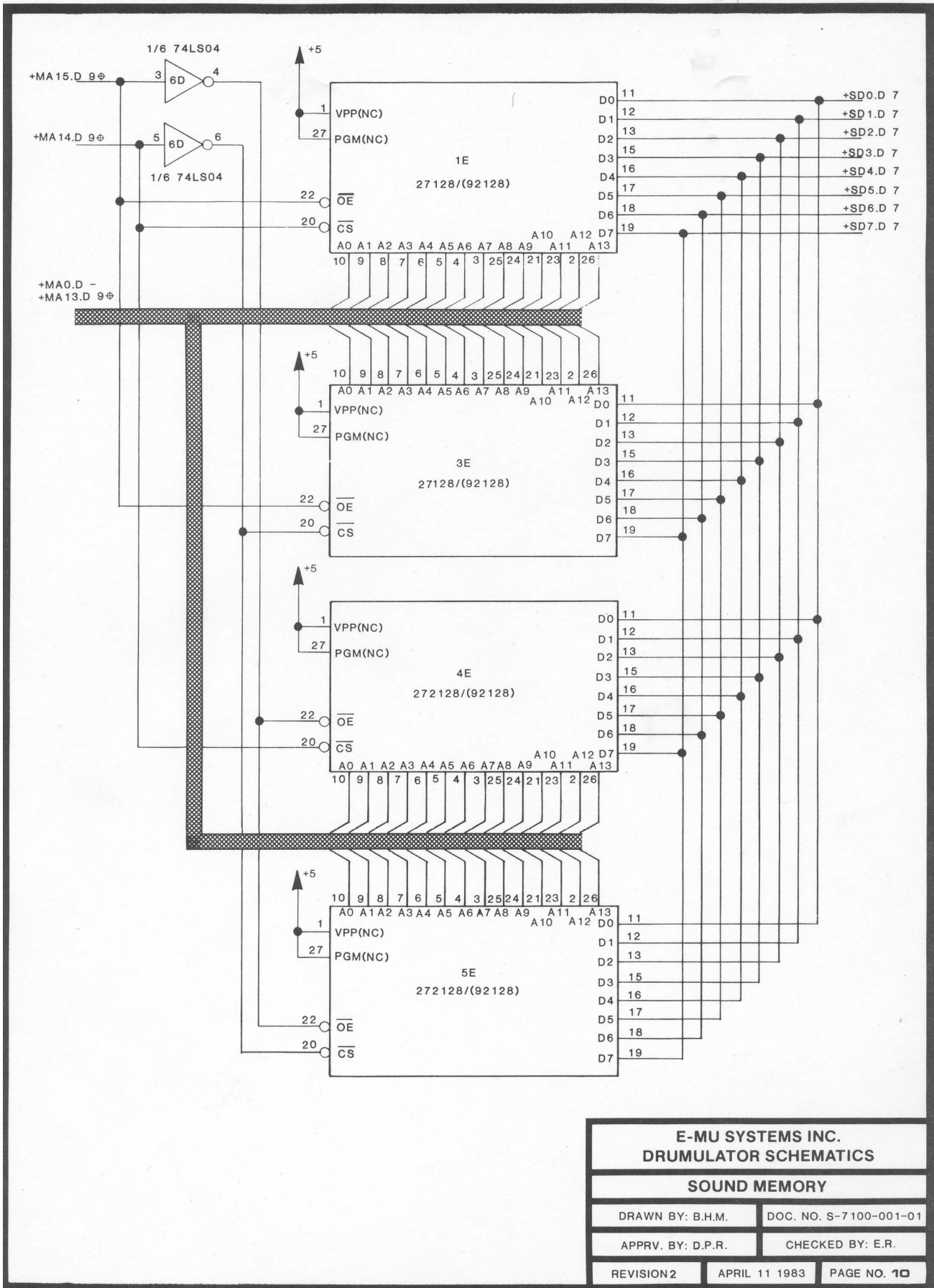

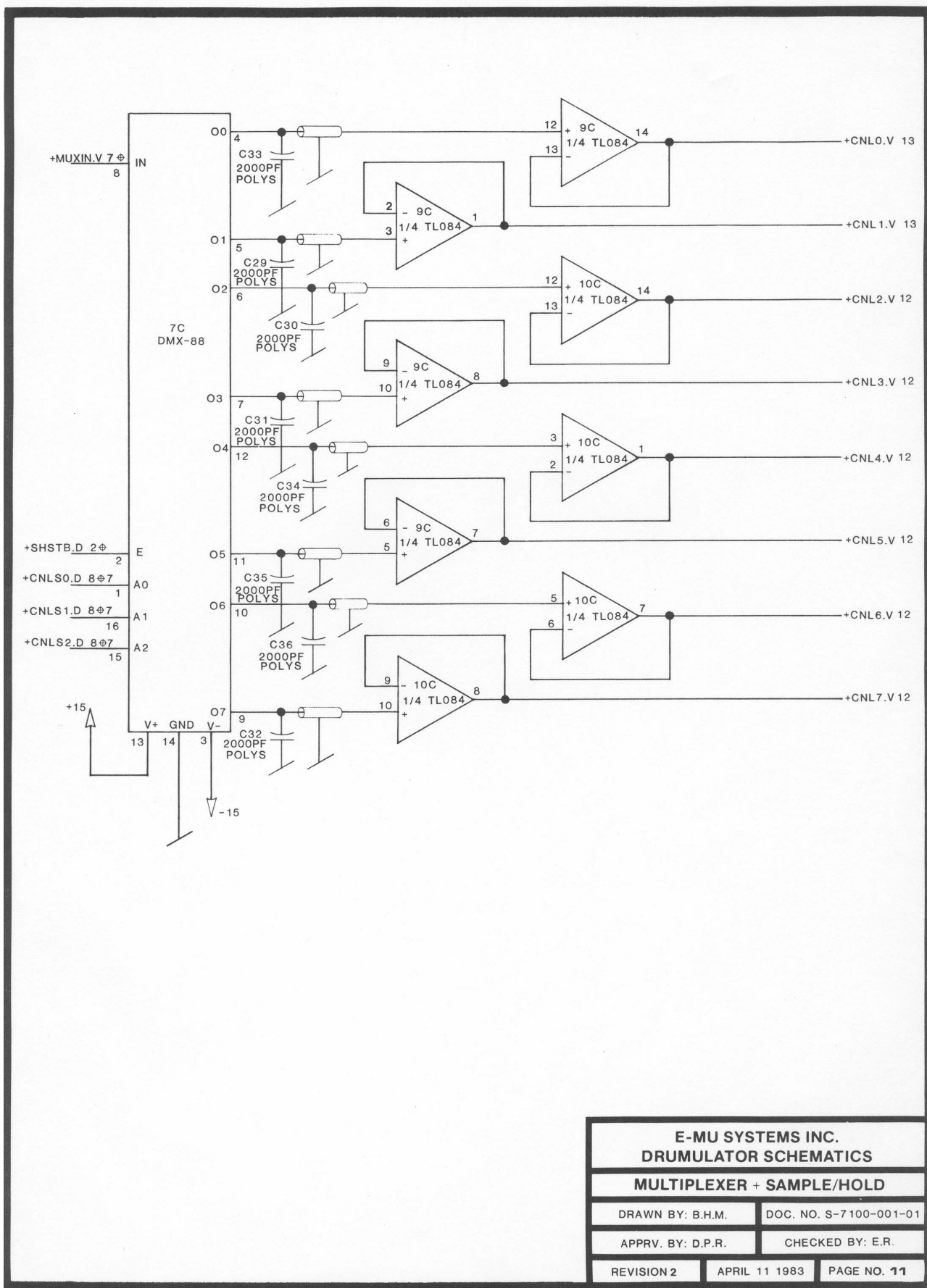

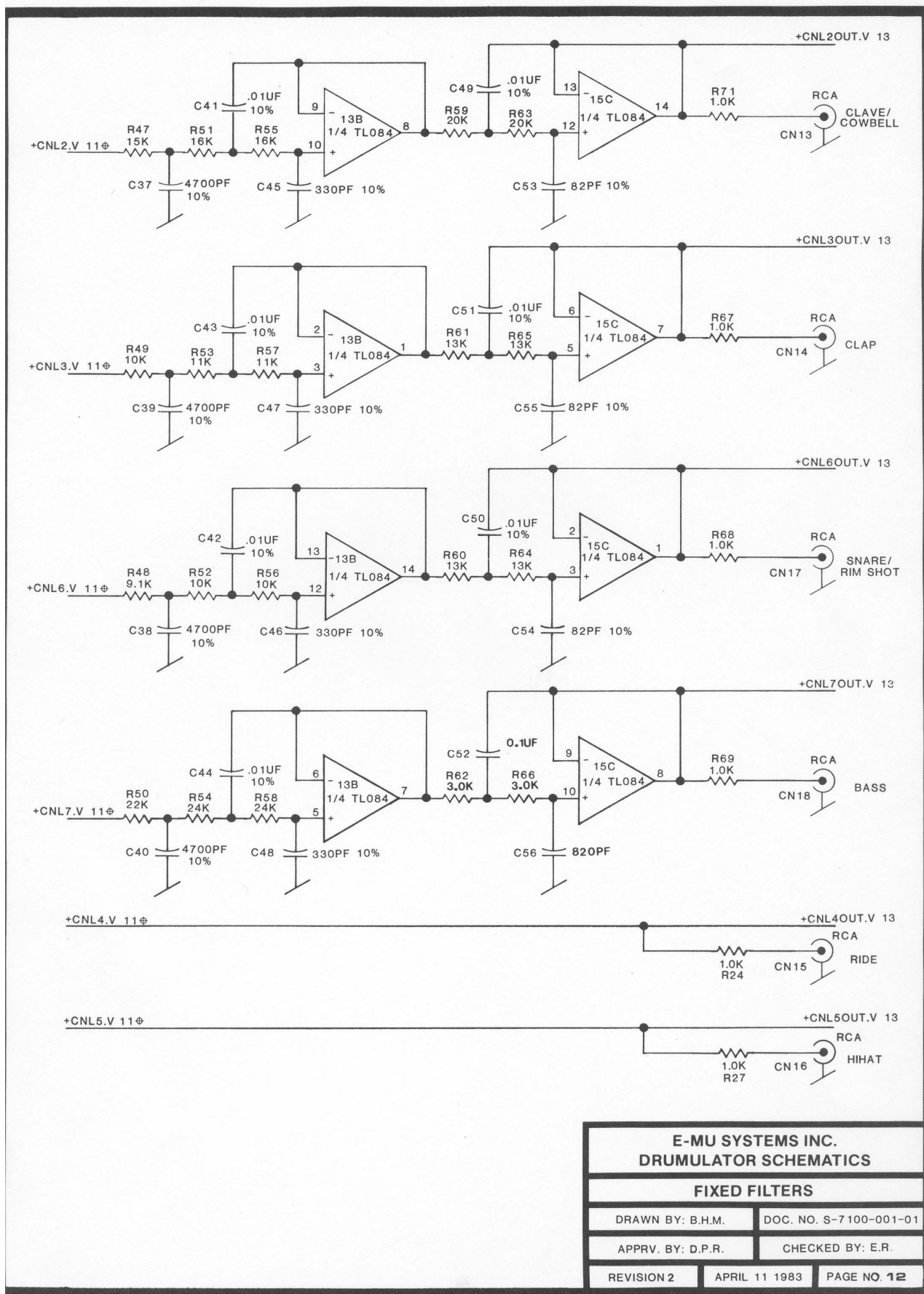

<b>E-MU SYSTEMS INC.</b>	
<b>DRUMULATOR SCHEMATICS</b>	
<b>FIXED FILTERS</b>	
DRAWN BY: B.H.M.	DOC. NO. S-7100-001-01
APPRV. BY: D.P.R.	CHECKED BY: E.R.
REVISION 2	APRIL 11 1983
	PAGE NO. 12



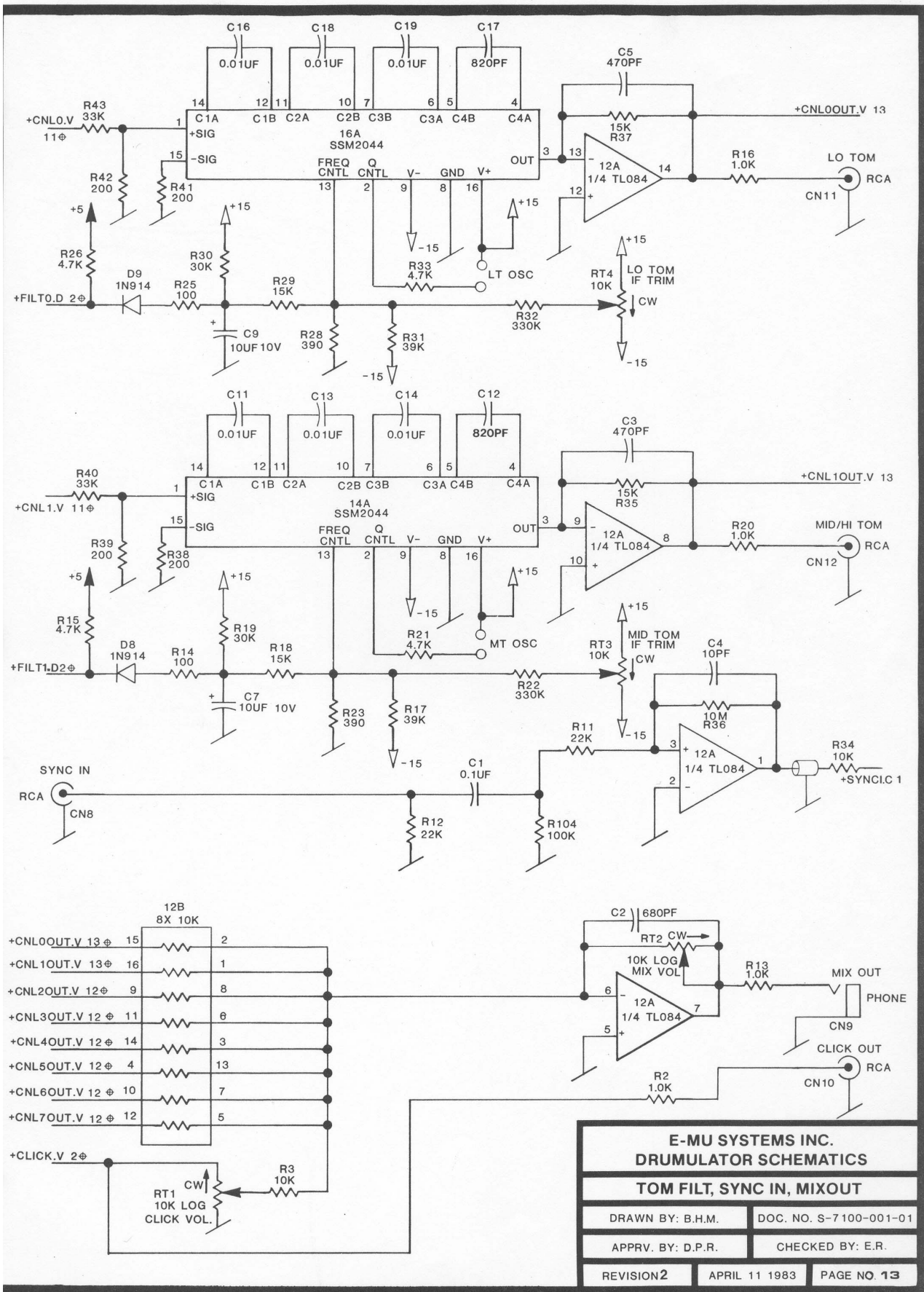

<b>E-MU SYSTEMS INC.</b>	
<b>DRUMULATOR SCHEMATICS</b>	
<b>TOM FILT, SYNC IN, MIXOUT</b>	
DRAWN BY: B.H.M.	DOC. NO. S-7100-001-01
APPRV. BY: D.P.R.	CHECKED BY: E.R.
REVISION 2	APRIL 11 1983
	PAGE NO. 13

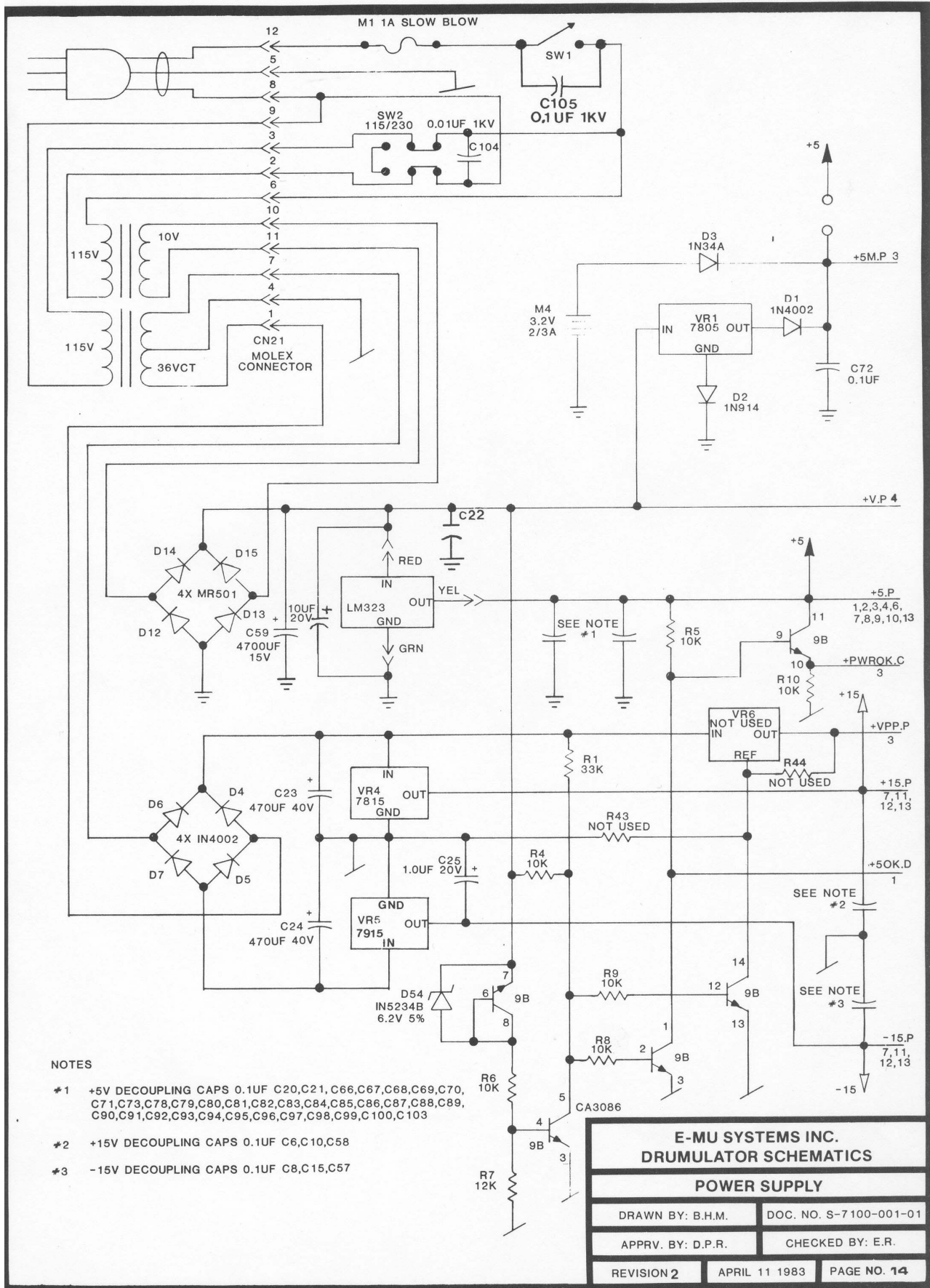

## 7 Drumulator Signal Name Definitions

The signal names are comprised of: (a) + or - specifying active high or low. (b) An abbreviation of the signal function. (c) An abbreviation of the signal type. (d) The signal's destination and source page numbers. Source page is indicated by an ⊕ following the page number. If there is no ⊕ after a page number then the present page is the source page. If the present page is listed with the destination page numbers then the signal appears again on the same page.

EXAMPLE: (a) (b) (c) (d)  
- CSWHI .D 2⊕, 9

(a) (b) (c) (d)  
(Low) (Chip select to write high sound address) (TTL) (Source pg 2, destination 9).

Ground Symbols Definition:

Digital Ground



Analog Ground



Chassis Ground



Bus Symbol Definitions:

Data Bus

Register Address Bus

Address Bus

Register Data Bus

Level Control Bus

Sum Output Address Bus

Memory Address Bus

Drumulator Signal Name List:

Name	Source	Destination	Type	Description
+D0.T	1	1,2,3,4,8,9.	TRISTATE	DATA BUS 0 LSB
+D1.T	1	1,2,3,4,7,8,9.	TRISTATE	DATA BUS 1
+D2.T	1	1,2,3,4,7,8,9.	TRISTATE	DATA BUS 2
+D3.T	1	1,2,3,4,7,8,9.	TRISTATE	DATA BUS 3
+D4.T	1	1,2,3,4,7,9.	TRISTATE	DATA BUS 4
+D5.T	1	1,2,3,4,7,9.	TRISTATE	DATA BUS 5
+D6.T	1	1,2,3,4,7,9.	TRISTATE	DATA BUS 6
+D7.T	1	1,2,3,4,7,9.	TRISTATE	DATA BUS 7 MSB
+A0.D	1	1,2,3.	TTL	CPU ADDRESS BUS 0 LSB
+A1.D	1	1,2,3.	TTL	CPU ADDRESS BUS 1
+A2.D	1	2,3.	TTL	CPU ADDRESS BUS 2
+A3.D	1	1,3.	TTL	CPU ADDRESS BUS 3
+A4.D	1	2,3.	TTL	CPU ADDRESS BUS 4
+A5.D	1	2,3.	TTL	CPU ADDRESS BUS 5
+A6.D	1	3.	TTL	CPU ADDRESS BUS 6
+A7.D	1	3.	TTL	CPU ADDRESS BUS 7
+A8.D	1	3.	TTL	CPU ADDRESS BUS 8
+A9.D	1	3.	TTL	CPU ADDRESS BUS 9
+A10.D	1	3.	TTL	CPU ADDRESS BUS 10
+A11.D	1	3.	TTL	CPU ADDRESS BUS 11
+A12.D	1	3.	TTL	CPU ADDRESS BUS 12
+A13.D	1	3.	TTL	CPU ADDRESS BUS 13
+A14.D	1	3.	TTL	CPU ADDRESS BUS 14
-MREQ.D	1	3.	TTL	CPU MEMORY REQUEST
-IORQ.D	1	1,2.	TTL	CPU INPUT/OUTPUT REQUEST
-RD.D	1	1,2.	TTL	CPU READ REQUEST
-WR.D	1	2.	TTL	CPU WRITE REQUEST
-MEMWR.D	1	3.	TTL	CPU MEMORY WRITE REQUEST
-MEMRD.D	1	3.	TTL	CPU MEMORY READ REQUEST
-M1.D	1	1.	TTL	CPU INSTRUCTION FETCH
+PHI.D	2	1.	TTL	CPU CLOCK
-CLK.D	2	1,8.	TTL	MICROCONTROLLER CLOCK

Name	Source	Destination	Type	Description
+SYNCL.C	13	1.	CMOS	SYNC/CASSETTE INPUT
-CSWPOT.D	2	1.	TTL	CHIP SEL. TO WRITE POT 1 SHOT
-EERDY.D	3	1.	TTL	EEPROM WRITE READ
-CSRPB.D	2	1,3,4.	TTL	CHIP SELECT TO READ PUSHBUTT
+SHD.D	8	2.	TTL	SAMPLE/HOLD STROBE LATCH DAT
+SHSTB.D	2	11.	TTL	SAMPLE/HOLD STROBE
-CSWLO.D	2	9.	TTL	CHP SEL-WRITE LO SOUND ADDR
-CSWHI.D	2	8,9.	TTL	CHP SEL-WRITE HI SOUND ADDR
-CSWAD.D	2	7,8.	TTL	CHP SEL-WRITE SOUNDCHAN DAT
-CSWPBL.D	2	2.	TTL	CHP SEL-WRITE PUSHBUT LATCH
-CSWDISP.D	2	4.	TTL	CHP SEL-WRITE DISPLAY LATCH
-CSWCLICK.D	2	2.	TTL	CHP SEL-WRITE CLICK 1SHOT
-CSWSYNC.D	2	2.	TTL	CHP SEL-WRITE SYN/CASS LATCH
+PBSEL0.D	2	4.	TTL	PUSHBUTT DECODE STROBE 0 LSB
+PBSEL1.D	2	4.	TTL	PUSHBUTT DECODE STROBE 1
+PBSEL2.D	2	4.	TTL	PUSHBUTT DECODE STROBE 2 MSB
+DSPSEL0.D	2	4.	TTL	DISPLAY DECODE STROBE 0 LSB
+DSPSEL1.D	2	4.	TTL	DISPLAY DECODE STROBE 1
+DSPSEL2.D	2	4.	TTL	DISPLAY DECODE STROBE 2 MSB
+FILT0.D	2	13.	TTL	VCF TRIGGER CHANNEL 0
+FILT1.D	2	13.	TTL	VCF TRIGGER CHANNEL 1
+CLICK.V	2	13.	ANAL.VOLT.	METRONOME CLICK
+VPP.P	14	3.	POWER	EEPROM PROGRAMMING VOLTAGE
+5M.P	14	3.	POWER	+5 SUPPLY FOR MEMORY
+PWROK.C	14	3.	CMOS	+5 POWER OK SIGNAL
+V.P	14	4.	POWER	UNREGULATED SUPPLY FOR LED
+5.P	14	1-4,6-10,13.	POWER	+5 SUPPLY
+15.P	14	7,11,12,13.	POWER	+15 SUPPLY
+5OK.D	14	1.	TTL	+5 VOLTAGE OK SIGNAL
-15.P	14	7,11,12,13.	POWER	-15 SUPPLY
-BUS0.D	4	6.	TTL	PUSHBUTTON BUS 0 DRIVE
-BUS1.D	4	6.	TTL	PUSHBUTTON BUS 1 DRIVE
-BUS2.D	4	6.	TTL	PUSHBUTTON BUS 2 DRIVE
-BUS3.D	4	6.	TTL	PUSHBUTTON BUS 3 DRIVE
-BUS4.D	4	6.	TTL	PUSHBUTTON BUS 4 DRIVE
-BUS5.D	4	6.	TTL	PUSHBUTTON BUS 5 DRIVE
-BUS6.D	4	6.	TTL	PUSHBUTTON BUS 6 DRIVE
-BUS7.D	4	6.	TTL	PUSHBUTTON BUS 7 DRIVE
-CON0.C	6	4.	CMOS	CONTACT 0 PUSHBUTTON OUTPUT
-CON1.C	6	4.	CMOS	CONTACT 1 PUSHBUTTON OUTPUT
-CON2.C	6	4.	CMOS	CONTACT 2 PUSHBUTTON OUTPUT
-CON3.C	6	4.	CMOS	3 PUSHBUTTON OUTPUT
+ANOD0.V	4	5.	ANAL.VOLT	DISPLAY ANODE 0 DRIVE
+ANOD1.V	4	5.	ANAL.VOLT	DISPLAY ANODE 1 DRIVE
+ANOD2.V	4	5.	ANAL.VOLT	DISPLAY ANODE 2 DRIVE
+ANOD3.V	4	5.	ANAL.VOLT	DISPLAY ANODE 3 DRIVE
+ANOD4.V	4	5.	ANAL.VOLT	DISPLAY ANODE 4 DRIVE
-CATH0.I	4	5.	CURRENT	DISPLAY CATHODE 0 DRIVE
-CATH1.I	4	5.	CURRENT	DISPLAY CATHODE 1 DRIVE
-CATH2.I	4	5.	CURRENT	DISPLAY CATHODE 2 DRIVE
-CATH3.I	4	5.	CURRENT	DISPLAY CATHODE 3 DRIVE
-CATH4.I	4	5.	CURRENT	DISPLAY CATHODE 4 DRIVE
-CATH5.I	4	5.	CURRENT	DISPLAY CATHODE 5 DRIVE
-CATH6.I	4	5.	CURRENT	DISPLAY CATHODE 6 DRIVE
-CATH7.I	4	5.	CURRENT	DISPLAY CATHODE 7 DRIVE
+CNLS0.D	8	7,11.	TTL	CHANNEL SELECT 0 LSB
+CNLS1.D	8	7,11.	TTL	CHANNEL SELECT 1
+CNLS2.D	8	7,11.	TTL	CHANNEL SELECT 2
-WRP.D	8	9.	TTL	uC. RAM WRITE PULSE
-IOE.D	8	9.	TTL	uC. INPUT LATCH OUTPUT ENABL
-SOE.D	8	9.	TTL	uC. SUM LATCH OUTPUT ENABLE
-DLE.D	8	9.	TTL	uC. DATA LATCH CONTROL ENABL
+CLK.D	8	9.	TTL	uC. CLOCK
+RA0.D	8	9.	TTL	uC. RAM ADDRESS 0 LSB
+RA1.D	8	9.	TTL	uC. RAM ADDRESS 1
+RA2.D	8	9.	TTL	uC. RAM ADDRESS 2

Name	Source	Destination	Type	Description
+RA3.D	8	9.	TTL	uC. RAM ADDRESS 3 MSB
+CARRY.D	9	8.	TTL	uC. ADDER CARRY OUTPUT
+MA0.D	9	10.	TTL	SOUND ROM ADDRESS 0 LSB
+MA1.D	9	10.	TTL	SOUND ROM ADDRESS 1
+MA2.D	9	10.	TTL	SOUND ROM ADDRESS 2
+MA3.D	9	10.	TTL	SOUND ROM ADDRESS 3
+MA4.D	9	10.	TTL	SOUND ROM ADDRESS 4
+MA5.D	9	10.	TTL	SOUND ROM ADDRESS 5
+MA6.D	9	10.	TTL	SOUND ROM ADDRESS 6
+MA7.D	9	10.	TTL	SOUND ROM ADDRESS 7
+MA8.D	9	10.	TTL	SOUND ROM ADDRESS 8
+MA9.D	9	10.	TTL	SOUND ROM ADDRESS 9
+MA10.D	9	10.	TTL	SOUND ROM ADDRESS 10
+MA11.D	9	10.	TTL	SOUND ROM ADDRESS 11
+MA12.D	9	10.	TTL	SOUND ROM ADDRESS 12
+MA13.D	9	10.	TTL	SOUND ROM ADDRESS 13
+MA14.D	9	10.	TTL	SOUND ROM ADDRESS 14
+MA15.D	9	10.	TTL	SOUND ROM ADDRESS 15 MSB
+SD0.D	10	7.	TTL	SOUND ROM DATA 0 LSB
+SD1.D	10	7.	TTL	SOUND ROM DATA 1
+SD2.D	10	7.	TTL	SOUND ROM DATA 2
+SD3.D	10	7.	TTL	SOUND ROM DATA 3
+SD4.D	10	7.	TTL	SOUND ROM DATA 4
+SD5.D	10	7.	TTL	SOUND ROM DATA 5
+SD6.D	10	7.	TTL	SOUND ROM DATA 6
+SD7.D	10	7.	TTL	SOUND ROM DATA 7 MSB
+MUXIN.V	7	11.	ANAL.VOLT.	DAC OUTPUT—MULTIPLEX INPUT
+CNL0.V	11	13.	ANAL.VOLT.	CHANNEL 0 UNFILTERED SOUND
+CNL1.V	11	13.	ANAL.VOLT.	CHANNEL 1 UNFILTERED SOUND
+CNL2.V	11	12.	ANAL.VOLT.	CHANNEL 2 UNFILTERED SOUND
+CNL3.V	11	12.	ANAL.VOLT.	CHANNEL 3 UNFILTERED SOUND
+CNL4.V	11	12.	ANAL.VOLT.	CHANNEL 4 UNFILTERED SOUND
+CNL5.V	11	12.	ANAL.VOLT.	CHANNEL 5 UNFILTERED SOUND
+CNL6.V	11	12.	ANAL.VOLT.	CHANNEL 6 UNFILTERED SOUND
+CNL7.V	11	12.	ANAL.VOLT.	CHANNEL 7 UNFILTERED SOUND
+CNL0OUT.V	13	13.	ANAL.VOLT.	CHANNEL 0 FINAL OUTPUT
+CNL1OUT.V	13	13.	ANAL.VOLT.	CHANNEL 1 FINAL OUTPUT
+CNL2OUT.V	12	13.	ANAL.VOLT.	CHANNEL 2 FINAL OUTPUT
+CNL3OUT.V	12	13.	ANAL.VOLT.	CHANNEL 3 FINAL OUTPUT
+CNL4OUT.V	12	13.	ANAL.VOLT.	CHANNEL 4 FINAL OUTPUT
+CNL5OUT.V	12	13.	ANAL.VOLT.	CHANNEL 5 FINAL OUTPUT
+CNL6OUT.V	12	13.	ANAL.VOLT.	CHANNEL 6 FINAL OUTPUT
+CNL7OUT.V	12	13.	ANAL.VOLT.	CHANNEL 7 FINAL OUTPUT

## 8

# Drumulator Specifications

### Controls

#### Play Section

**Run/Stop** — Starts and stops playback of segments and songs. LED lights when running and flashes to indicate the beginning of a segment.

**Play Buttons (1-4)** — Used to play and program the drum sounds. Sounds are assigned by pressing and holding a Play button and then pressing either a Sound Select button or (to assign an accented sound) the Accent button followed by a Sound Select button. Any sound may be assigned to any Play button and a sound may be assigned to multiple buttons.

#### Parameter Control

**Tempo** — Used with the slider to program the tempo (in beats per minute) of each song, and to program tempo changes within a song.

**Accent** — Used with the slider to program the individual accent level of each instrument for each song.

**Level** — Used with the slider to program the mix level of each instrument for each song.

#### Sound Selection

**Drums/Perc.** — Toggles the function of the Sound Select buttons between drum sounds (lower labels) and percussion sounds (upper labels). LEDs indicate the current state.

**Sound Select (1-6)** — Select the sounds to be assigned to each play button. Also used to enter numerical data, to set the Auto Correct resolution, and to set the metronome and trigger rate.

**Met/Trig (7)** — Used in combination with the Select buttons to set the metronome rate (i.e., quarter note, eighth note triplet, etc.) and to program the trigger output in Song Mode.

**Mem (8)** — Pressed to display the amount of unused memory remaining.

### Programming Section

Programming the Drumulator is a two level process. Segment Mode is used to create short rhythmic patterns (typically a few measures in length). In Song Mode these segments are linked together into complete songs. The functions of the programming buttons depend on which mode the Drumulator is in.

**Song/Segment** — Toggles the Drumulator between Song and Segment modes. The LEDs indicate the current state.

#### Segment Mode

**Auto Correct** — Sets the resolution at which the Drumulator corrects rhythmic inaccuracies in your playing.

**Swing** — Adjusts the degree of "swing" in previously recorded segments (hard to describe, easy to hear).

**Copy** — Allows the copying of one segment into another segment number and the appending of a segment to itself from one to eight times.

**Measure Length** — Sets a segment's time signature.

**Segment Length** — Sets the number of measures in a segment.

**Erase** — Used to erase entire segments, a particular instrument within a segment, and specific notes within a segment.

**Record** — Pressed along with the Run/Stop button to enter Record Mode.

**Enter** — Enters programming data into the Drumulator.

#### Song Mode

**Select** — Selects the song to be programmed or played. Used with the Run/Stop button to start playback anywhere in the middle of a song. Used with the Tempo button to program tempo changes within a song. Used with the Level button to copy mix and accent data from one song to another.

**Repeat** — Defines repeat loops within a song. Loops may be repeated a preprogrammed number of times or can be set to repeat indefinitely until cued to continue by pressing the Repeat button or Repeat footswitch during playback.

**End** — Marks the end of a song. Songs may end and stop, end and repeat, or end and link to another song.

**"<" and ">"** — Used to step forward and backward through a song for purposes of programming or editing.

**Insert** — Allows data to be inserted into the middle of an existing song.

**Delete** — Causes data to be deleted from an existing song.

**Enter** — Same as in Segment Mode.

#### Level

**Mix Volume** — Sets the level of the mono mix output. Does not affect the separate channel outputs.

**Metronome Volume** — Sets the level of the metronome, trigger, and signal "beeps" in the mix output. Does not affect the independent Met/Trig output.

#### Cassette

**Cassette** — Places the Drumulator in Cassette Mode. In this mode buttons 7 and 8 are used to store songs and segments in digital form on standard audio tape and to reload previously stored data into the Drumulator.

#### External Clock

**External Clock** — Allows the Drumulator to be controlled by clocks from synthesizers, sequencers, and other drum machines. The Drumulator includes a programmable clock divider function which will convert incoming clock signals to the correct frequency for controlling the Drumulator.

#### Footswitch Controls

**Run/Stop** — Duplicates the function of the Run/Stop button.

**Repeat** — When running in Song Mode, pressing the repeat footswitch causes the Drumulator to exit from repeat loops. When stopped in Song Mode, pressing this footswitch causes the Drumulator to step to the next song.

### Specifications

**Sounds** — Twelve, digitally recorded: Bass, Snare, Rim, High Tom, Mid Tom, Low Tom, Clave, Cowbell, Hand Claps, Open Hi Hat, Closed Hi Hat, Ride Cymbal.

**Storage Capacity** — 36 Segments, 8 Songs.

**Maximum Memory Capacity** — 10,088 notes.

**Maximum Song Length** — 6 hours.

**Measure Length** — 1-99 beats (in units of quarter, eighth, or sixteenth notes).

**Segment Length** — 1-99 measures.

**Song Length** — 1-99 steps (a step may contain a segment, repeat sign, tempo change, or trigger information).

**Auto Correction Resolution** — Selectable: 8th note, 8th triplet, 16th note, 16th triplet, 32nd note, 32nd triplet, High Resolution.

**Tempo Range** — 40-240 BPM.

**Clock Rate** — 24 clicks per quarter note.

**External Trigger Threshold** — 1.5 volts.

**Audio Outputs (10)** — Mono mix, metronome/trigger, 8 individual instrument channels (bass, snare/rim, hi/mid toms, low toms, clave/cowbell, claps, open/closed hi hat, ride).

**Trigger Inputs (4)** — Parallel the 4 Play buttons.

**Cassette/External Clock Input** — In Cassette Mode, accepts data from an audio tape recorder. In External Clock Mode, accepts a clock at 24 clicks per quarter note or at any integer multiple of 24 with programmable divide down.

**Cassette/External Clock Output** — In Cassette Mode, outputs digital data for storage on an audio tape recorder or Emulator disk. Otherwise, outputs internal clock at a rate 24 clicks per quarter note whenever the Drumulator is running.

**Cassette Dump and Load Time** — 15 seconds.

**Computer Interface** — The Drumulator can be controlled by any computer equipped with an RS-232, 9600 baud, eight bit serial interface (contact factory for details).

**Power Requirements** — 115v/230v; 60Hz/50Hz; 42W max.

Specifications subject to change without notice.

---

**9**

**ECOs**

---

**E-mu Systems, Inc.**  
 applied magic for the arts

**ENGINEERING CHANGE ORDER**

E.C.O. No: 039

Date: 3/25/83 E.C.O. By: D. Rossum Approval: T.W.M. Chief Engineer: [Signature]

Confidential: \_\_\_\_\_ Customer Release:

Affects Product: Drumulator Affects Assembly: Regulator Socket/PCB, Rev 1

Serial Nos. Modified in Production: 20 and up

Notation to Modify Units in Repair: See: A-7501-011-01 (4-12-83)

Approximate Starting Serial No. for New Documents: \_\_\_\_\_  
(visual check or call factory to verify)

P.C.B. Serial No. 12 and up

Purpose of Change: Reduce susceptibility of Drumulator to power line spikes.

**PRIORITY OF CHANGE:**

For Future Units:  Modify Units in Production:

Modify all Units Available for Repair:  Modify All Field Units:

**PARTS AFFECTED:**

Reference Designator		Description		Part Number	
Old	New	Old	New	Old	New
C-22	----	10UF 20V Tan	Remains same	C-317	same
_____	_____	_____	_____	_____	_____
_____	_____	_____	_____	_____	_____
_____	_____	_____	_____	_____	_____
_____	_____	_____	_____	_____	_____

**\*\*FULL DESCRIPTION OF CHANGES ON REVERSE SIDE & ATTACHED DOCUMENTS\*\***

**FOR E-MU SYSTEMS, INC. USE ONLY:**

Documents Affected	Page No.	Deliver to Production	Deliver to Purchasing	Obsolete Copies Filed	Performed By	Date
<input checked="" type="checkbox"/> Schematic	<u>14</u>	<input checked="" type="checkbox"/>	_____	<input checked="" type="checkbox"/>	<u>BHM</u>	<u>3/28</u>
_____ Software	_____	_____	_____	_____	_____	_____
_____ Parts List	_____	_____	_____	_____	_____	_____
<input checked="" type="checkbox"/> Assy. Diag.	_____	<input checked="" type="checkbox"/>	_____	<input checked="" type="checkbox"/>	<u>BHM</u>	<u>3/28</u>
_____ P.C.B Masters	_____	_____	_____	_____	_____	_____
_____ P.C.B. Films	_____	_____	_____	_____	_____	_____
_____ Dimensional Diag.	_____	_____	_____	_____	_____	_____
_____ Package Master Art	_____	_____	_____	_____	_____	_____
_____ Package Films	_____	_____	_____	_____	_____	_____
_____ Other: _____	_____	_____	_____	_____	_____	_____
_____ Other: _____	_____	_____	_____	_____	_____	_____

E.C.O. Completed and Filed By: Brian H. Monahan Date: 3/28/83

E.E106-011-01



Schematic Diagram: Old

New

Mechanical Diagram: Old

1. Eliminate C-22 10UF 20V Tantalum from PCB.

New

2. Attach 10UF 20V Tantalum Capacitor to Regulator Socket from ground (green = C) to input (red = B). Positive of Cap to red.



TOP VIEW  
(WIRES NOT SHOWN)

10UF 25V TANTALUM CAPACITOR (C-317) SOLDERED TO THE BASE OF THE GND AND "B" LUGS. PLUS SIDE OF CAPACITOR TO "B" LUG.

**E-mu Systems, Inc.**  
 applied magic for the arts

**ENGINEERING CHANGE ORDER**

E.C.O. No: 040  
 Date: 4/4/83 E.C.O. By: E. Rudnick Approval: T.W.M. Chief Engineer: R  
 Confidential:  Customer Release:   
 Affects Product: Drumulator Affects Assembly: Drumulator PCB DA-303, Rev 1  
 Serial Nos. Modified in Production: 70  
 Notation to Modify Units in Repair: (see reverse)  
 Approximate Starting Serial No. for New Documents: 70  
(visual check or call factory to verify)  
 P.C.B. Serial No. 122  
 Purpose of Change: To raise Slider Shaft 1/16" to increase knob clearance above housing.

**PRIORITY OF CHANGE:**

For Future Units:  Modify Units in Production:   
 Modify all Units Available for Repair:  Modify All Field Units:

**PARTS AFFECTED:**

Reference Designator		Description		Part Number	
Old	New	Old	New	Old	New
		#4 x 3/16"	#4 x 1/8"	H-305	same
		metal spacers	nylon spacers		

**\*\*FULL DESCRIPTION OF CHANGES ON REVERSE SIDE & ATTACHED DOCUMENTS\*\***

**FOR E-MU SYSTEMS, INC. USE ONLY:**

Documents Affected	Page No.	Deliver to Production	Deliver to Purchasing	Obsolete Copies Filed	Preformed By	Date
<input type="checkbox"/> Schematic						
<input type="checkbox"/> Software						
<input checked="" type="checkbox"/> Parts List		<input checked="" type="checkbox"/>			BHM	4/10
<input checked="" type="checkbox"/> Assy. Diag.		<input checked="" type="checkbox"/>			BHM	4/10
<input type="checkbox"/> P.C.B Masters						
<input type="checkbox"/> P.C.B. Films						
<input type="checkbox"/> Dimensional Diag.						
<input type="checkbox"/> Package Master Art						
<input type="checkbox"/> Package Films						
<input type="checkbox"/> Other: _____						
<input type="checkbox"/> Other: _____						

E.C.O. Completed and Filed By: Brian H. Monahan Date: 4/10/83

Schematic Diagram: Old

New

Mechanical Diagram: Old

New

1. Slider is spaced off board by 2 #4 x 3/16" metal spacers, (part# H-305).

2. Change spacer spec to 2 #4 x 1/8" (.125), nylon. (part #H-305)  
Update available units with new spacers.

PROCEDURE:

1. Remove bottom cover and PCB.
2. Desolder slider wires and remove screws and spacers.
3. Reinstall slider in same orientation with new spacers.
4. Reinstall PCB carefully, check for bent LEDS.
5. Reinstall bottom cover and test unit.

**E-mu Systems, Inc.**  
 applied magic for the arts

**ENGINEERING CHANGE ORDER**

E.C.O. No: 040  
 Date: 4/4/83 E.C.O. By: E. Rudnick Approval: T.W.M. Chief Engineer: R  
 Confidential:  Customer Release:   
 Affects Product: Drumulator Affects Assembly: Drumulator PCB DA-303, Rev 1  
 Serial Nos. Modified in Production: 70  
 Notation to Modify Units in Repair: (see reverse)  
 Approximate Starting Serial No. for New Documents: 70  
 P.C.B. Serial No. 122 (visual check or call factory to verify)  
 Purpose of Change: To raise Slider Shaft 1/16" to increase knob clearance above housing.

**PRIORITY OF CHANGE:**

For Future Units:  Modify Units in Production:   
 Modify all Units Available for Repair:  Modify All Field Units:

**PARTS AFFECTED:**

Reference Designator		Description		Part Number	
Old	New	Old	New	Old	New
		#4 x 3/16"	#4 x 1/8"	H-305	same
		metal spacers	nylon spacers		

**\*\*FULL DESCRIPTION OF CHANGES ON REVERSE SIDE & ATTACHED DOCUMENTS\*\***

**FOR E-MU SYSTEMS, INC. USE ONLY:**

Documents Affected	Page No.	Deliver to Production	Deliver to Purchasing	Obsolete Copies Filed	Preformed By	Date
<input type="checkbox"/> Schematic						
<input type="checkbox"/> Software						
<input checked="" type="checkbox"/> Parts List		<input checked="" type="checkbox"/>			BHM	4/10
<input checked="" type="checkbox"/> Assy. Diag.		<input checked="" type="checkbox"/>			BHM	4/10
<input type="checkbox"/> P.C.B Masters						
<input type="checkbox"/> P.C.B. Films						
<input type="checkbox"/> Dimensional Diag.						
<input type="checkbox"/> Package Master Art						
<input type="checkbox"/> Package Films						
<input type="checkbox"/> Other: _____						
<input type="checkbox"/> Other: _____						

E.C.O. Completed and Filed By: Brian H. Monahan Date: 4/10/83

Schematic Diagram: Old

New

Mechanical Diagram: Old

New

1. Slider is spaced off board by 2 #4 x 3/16" metal spacers, (part# H-305).

2. Change spacer spec to 2 #4 x 1/8" (.125), nylon. (part #H-305)  
Update available units with new spacers.

PROCEDURE:

1. Remove bottom cover and PCB.
2. Desolder slider wires and remove screws and spacers.
3. Reinstall slider in same orientation with new spacers.
4. Reinstall PCB carefully, check for bent LEDS.
5. Reinstall bottom cover and test unit.

**E-mu Systems, Inc.**  
 applied magic for the arts

**ENGINEERING CHANGE ORDER**

E.C.O. No: 042

Date: 4/6/83 E.C.O. By: D. Rossum Approval: T.W.M. Chief Engineer: M

Confidential:  Customer Release:

Affects Product: Drumulator Affects Assembly: Drumulator PCB DA-303 Rev 1

Serial Nos. Modified in Production: \_\_\_\_\_

Notation to Modify Units in Repair: \_\_\_\_\_

Approximate Starting Serial No. for New Documents: 253

(visual check or call factory to verify)

P.C.B. Serial No. 175

Purpose of Change: Minimize probability of backdate code 2044's unable to resonate.

**PRIORITY OF CHANGE:**

For Future Units:  Modify Units in Production:

Modify all Units Available for Repair:  Modify All Field Units:

**PARTS AFFECTED:**

Modify if unit won't resonate:

Reference Designator		Description		Part Number	
Old	New	Old	New	Old	New
R-21	same	10K	4.7K	R-309	R-307
R-33	same	10K	4.7K	R-309	R-307
_____	_____	_____	_____	_____	_____
_____	_____	_____	_____	_____	_____
_____	_____	_____	_____	_____	_____

**\*\*FULL DESCRIPTION OF CHANGES ON REVERSE SIDE & ATTACHED DOCUMENTS\*\***

**FOR E-MU SYSTEMS, INC. USE ONLY:**

Documents Affected	Page No.	Deliver to Production	Deliver to Purchasing	Obsolete Copies Filed	Performed By	Date
<input checked="" type="checkbox"/> Schematic	<u>13</u>	<input checked="" type="checkbox"/>	_____	_____	<u>BHM</u>	<u>5/16</u>
<input type="checkbox"/> Software	_____	_____	_____	_____	_____	_____
<input checked="" type="checkbox"/> Parts List	<u>2</u>	<input checked="" type="checkbox"/>	_____	_____	<u>BHM</u>	<u>5/16</u>
<input checked="" type="checkbox"/> Assy. Diag.	<u>2</u>	<input checked="" type="checkbox"/>	_____	_____	<u>BHM</u>	<u>5/16</u>
<input type="checkbox"/> P.C.B Masters	_____	_____	_____	_____	_____	_____
<input type="checkbox"/> P.C.B. Films	_____	_____	_____	_____	_____	_____
<input type="checkbox"/> Dimensional Diag.	_____	_____	_____	_____	_____	_____
<input type="checkbox"/> Package Master Art	_____	_____	_____	_____	_____	_____
<input type="checkbox"/> Package Films	_____	_____	_____	_____	_____	_____
<input type="checkbox"/> Other: _____	_____	_____	_____	_____	_____	_____
<input type="checkbox"/> Other: _____	_____	_____	_____	_____	_____	_____

E.C.O. Completed and Filed By: Brian H. Monahan Date: 5/16/83

E-F108-044-01

Schematic Diagram: Old

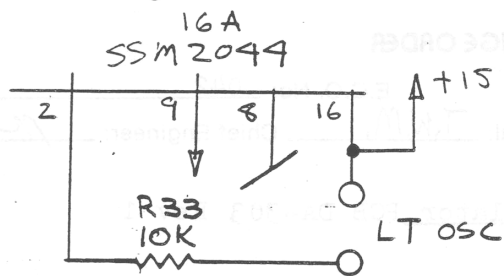

New

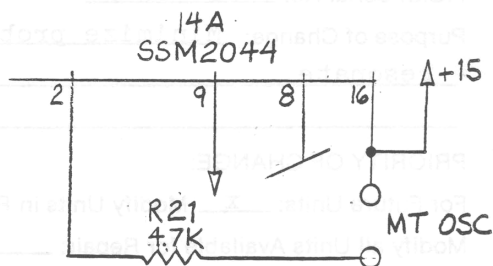
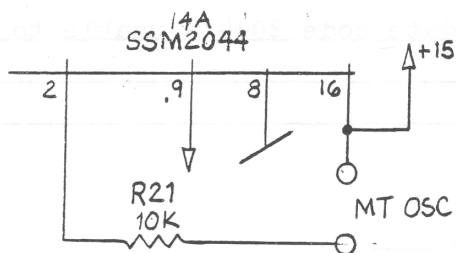
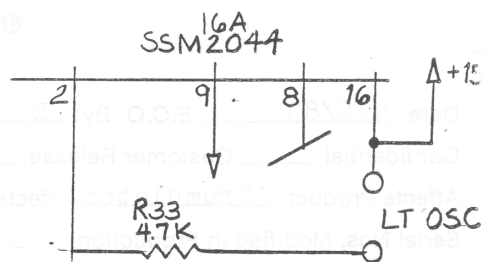

Mechanical Diagram: Old

New

**E-mu Systems, Inc.**  
 applied magic for the arts

**ENGINEERING CHANGE ORDER**

E.C.O. No: 043  
 Date: 4/11/83 E.C.O. By: D. Rossum Approval: T.W.M. Chief Engineer: [Signature]  
 Confidential:        Customer Release: X  
 Affects Product: Drumulator / Affects Assembly: Drumulator PCB DA-303, Rev 1  
 Serial Nos. Modified in Production: 7000  
 Notation to Modify Units in Repair:         
 Approximate Starting Serial No. for New Documents: 74  
(visual check or call factory to verify)  
 P.C.B. Serial No. 157  
 Purpose of Change: Allows operation below 100VAC, improves operation on low lin

**PRIORITY OF CHANGE:**

For Future Units: X Modify Units in Production:         
 Modify all Units Available for Repair:        Modify All Field Units:         
 PARTS AFFECTED:        Modify any unit that won't run on 100VAC: X

Reference Designator		Description		Part Number	
Old	New	Old	New	Old	New
R7	----	100K	12K	R-318	R-326
R105	D54	1.0M	6.2V 5% Zener	R-325	D-305
			1N5234B or equiv		

**\*\*FULL DESCRIPTION OF CHANGES ON REVERSE SIDE & ATTACHED DOCUMENTS\*\***

**FOR E-MU SYSTEMS, INC. USE ONLY:**

Documents Affected	Page No.	Deliver to Production	Deliver to Purchasing	Obsolete Copies Filed	Preformed By	Date
<u>X</u> Schematic		<u>X</u>			BHM	5/16
Software						
<u>X</u> Parts List		<u>X</u>			BHM	5/16
<u>X</u> Assy. Diag.		<u>X</u>			BHM	5/16
P.C.B Masters						
P.C.B. Films						
Dimensional Diag.						
Package Master Art						
Package Films						
Other: _____						
Other: _____						

E.C.O. Completed and Filed By: Brian H. Monahan Date: 5/16/83



Schematic Diagram: Old

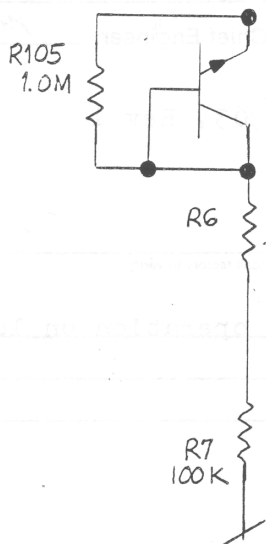

New

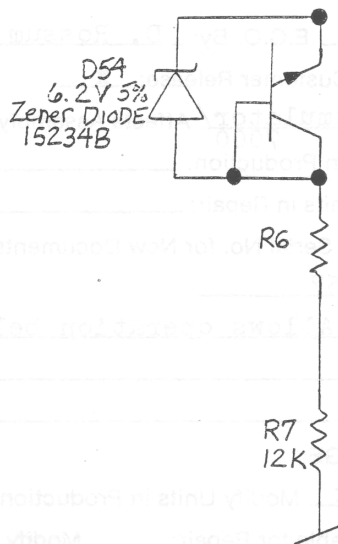

Mechanical Diagram: Old

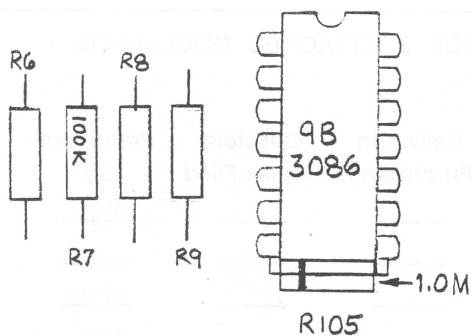

New

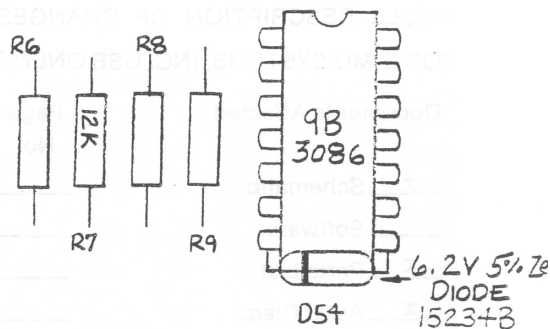

**E-mu Systems, Inc.**  
 applied magic for the arts

**ENGINEERING CHANGE ORDER**

E.C.O. No: 044  
 Date: 4/26/83 E.C.O. By: D. Rossum Approval: T.W.M. Chief Engineer: \_\_\_\_\_  
 Confidential: \_\_\_\_\_ Customer Release: X  
 Affects Product: Drumulator Affects Assembly: PCB rev 1  
 Serial Nos. Modified in Production: \_\_\_\_\_  
 Notation to Modify Units in Repair: \_\_\_\_\_  
 Approximate Starting Serial No. for New Documents: 682  
(visual check or call factory to verify)  
 P.C.B. Serial No. 700  
 Purpose of Change: To remove "buzz on Bass drum output.

**PRIORITY OF CHANGE:**

For Future Units: X Modify Units in Production: \_\_\_\_\_  
 Modify all Units Available for Repair: \_\_\_\_\_ Modify All Field Units: \_\_\_\_\_

**PARTS AFFECTED:**

Reference Designator		Description		Part Number	
Old	New	Old	New	Old	New
R62	same	30K	3.0K 5% 1/4 W.	R-315	R-327*
R66	same	30K	3.0K 5% 1/4 W.	R-315	R-327*
C52	same	0.01 uf 10%	0.1 20% @ <u>see below</u>	C-311	C-321*
C56	same	82pf 10%	820pf	C-303	C-307

\* New Drumulator part number. @ AUX SR 265E104MAA or equiv.

**\*\*FULL DESCRIPTION OF CHANGES ON REVERSE SIDE & ATTACHED DOCUMENTS\*\***

**FOR E-MU SYSTEMS, INC. USE ONLY:**

Documents Affected	Page No.	Deliver to Production	Deliver to Purchasing	Obsolete Copies Filed	Preformed By	Date
<u>X</u> Schematic	<u>12</u>	<u>X</u>	_____	<u>X</u>	<u>B.H.M.</u>	<u>5/16/83</u>
_____ Software	_____	_____	_____	_____	_____	_____
<u>X</u> Parts List	<u>2,3</u>	<u>X</u>	<u>X</u>	<u>X</u>	<u>B.H.M.</u>	<u>5/16/83</u>
<u>X</u> Assy. Diag.	<u>1</u>	<u>X</u>	<u>X</u>	<u>X</u>	<u>B.H.M.</u>	<u>5/16/83</u>
_____ P.C.B Masters	_____	_____	_____	_____	_____	_____
_____ P.C.B. Films	_____	_____	_____	_____	_____	_____
_____ Dimensional Diag.	_____	_____	_____	_____	_____	_____
_____ Package Master Art	_____	_____	_____	_____	_____	_____
_____ Package Films	_____	_____	_____	_____	_____	_____
_____ Other: _____	_____	_____	_____	_____	_____	_____
_____ Other: _____	_____	_____	_____	_____	_____	_____

E.C.O. Completed and Filed By: Brian H. Monahan Date: 5/16/83

E-F106-044-01

Schematic Diagram: Old

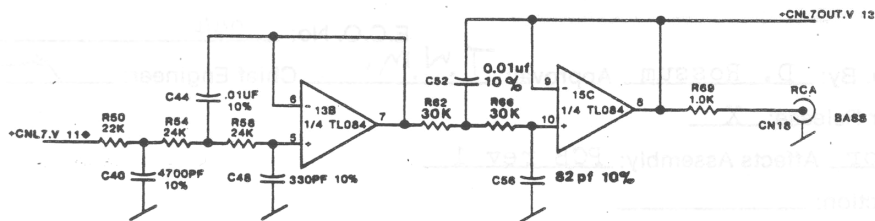

New

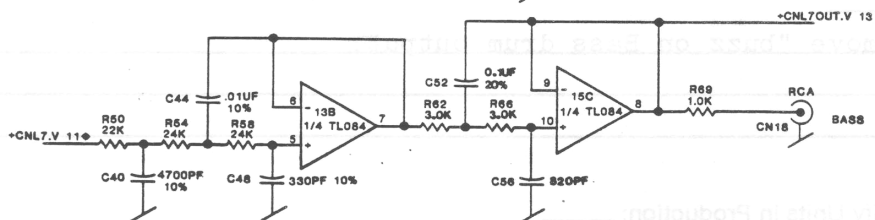

Mechanical Diagram:

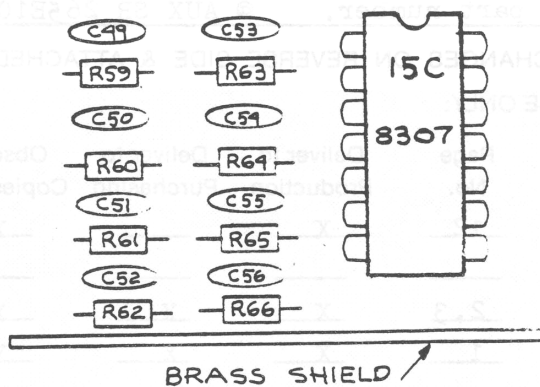

**E-mu Systems, Inc.**  
 applied magic for the arts

**ENGINEERING CHANGE ORDER**

E.C.O. No: 046  
 Date: 4/29/83 E.C.O. By: B. Monahan Approval: T.W.M. Chief Engineer: [Signature]  
 Confidential:  Customer Release:   
 Affects Product: Drum Rev 1 Affects Assembly: Drumulator PCB, Rev 1  
 Serial Nos. Modified in Production: \_\_\_\_\_  
 Notation to Modify Units in Repair: \_\_\_\_\_  
 Approximate Starting Serial No. for New Documents: 94  
(visual check or call factory to verify)  
 P.C.B. Serial No. 72  
 Purpose of Change: Enlarge anular ring area of all IC pads to prevent pads from lifting off when reworking.

**PRIORITY OF CHANGE:**

For Future Units:  Modify Units in Production:   
 Modify all Units Available for Repair:  Modify All Field Units:

**PARTS AFFECTED:**

Reference Designator		Description		Part Number	
Old	New	Old	New	Old	New

**\*\*FULL DESCRIPTION OF CHANGES ON REVERSE SIDE & ATTACHED DOCUMENTS\*\***

**FOR E-MU SYSTEMS, INC. USE ONLY:**

Documents Affected	Page No.	Deliver to Production	Deliver to Purchasing	Obsolete Copies Filed	Preformed By	Date
_____ Schematic	_____	_____	_____	_____	_____	_____
_____ Software	_____	_____	_____	_____	_____	_____
_____ Parts List	_____	_____	_____	_____	_____	_____
_____ Assy. Diag.	_____	_____	_____	_____	_____	_____
<input checked="" type="checkbox"/> P.C.B Masters	_____	<input checked="" type="checkbox"/>	<input checked="" type="checkbox"/>	_____	BHM	5/5
_____ P.C.B. Films	_____	_____	_____	_____	_____	_____
_____ Dimensional Diag.	_____	_____	_____	_____	_____	_____
_____ Package Master Art	_____	_____	_____	_____	_____	_____
_____ Package Films	_____	_____	_____	_____	_____	_____
_____ Other: _____	_____	_____	_____	_____	_____	_____
_____ Other: _____	_____	_____	_____	_____	_____	_____

E.C.O. Completed and Filed By: Brian H. Monahan Date: 5/5/83

E-F106-0114-01

Schematic Diagram: Old

New

Mechanical Diagram: Old

New

I.C. Pad Hole Dia. .036

I.C. Pad Hole Dia. .031

**E-mu Systems, Inc.**  
 applied magic for the arts

**ENGINEERING CHANGE ORDER**

Date: 5-17-83 E.C.O. By: B. Monahan Approval: T.W.M. E.C.O. No: 047 Chief Engineer: [Signature]

Confidential:  Customer Release:

Affects Product: Drumulator Affects Assembly: P.C.B.

Serial Nos. Modified in Production: N/A

Notation to Modify Units in Repair: N/A

Approximate Starting Serial No. for New Documents: 3000

P.C.B. Serial No. 3069 (visual check or call factory to verify)

Purpose of Change: Revise P.C.B. from Rev1 to Rev2 by incorporating all previous E.C.O.s. Remove T03 Socket Cable from P.C.B. Generate new Assembly AD-305 T03 Socket Cable.

**PRIORITY OF CHANGE:**

For Future Units:  Modify Units in Production:

Modify all Units Available for Repair:  Modify All Field Units:

**PARTS AFFECTED:**

Reference Designator		Description		Part Number	
Old	New	Old	New	Old	New
-----	-----	Rev1 P.C.B.	Rev2 P.C.B.	AD-303	same
-----	-----	-----	T03 Socket Cbl.	-----	AD-305
-----	-----	-----	-----	-----	-----
-----	-----	-----	-----	-----	-----
-----	-----	-----	-----	-----	-----

**\*\*FULL DESCRIPTION OF CHANGES ON REVERSE SIDE & ATTACHED DOCUMENTS\*\***

**FOR E-MU SYSTEMS, INC. USE ONLY:**

Documents Affected	Page No.	Deliver to Production	Deliver to Purchasing	Obsolete Copies Filed	Performed By	Date
____ Schematic	____	____	____	____	____	____
____ Software	____	____	____	____	____	____
<input checked="" type="checkbox"/> Parts List	<u>All</u>	<input checked="" type="checkbox"/>	<input checked="" type="checkbox"/>	<input checked="" type="checkbox"/>	<u>BHM</u>	<u>7-1</u>
<input checked="" type="checkbox"/> Assy. Diag.	<u>All</u>	<input checked="" type="checkbox"/>	____	<input checked="" type="checkbox"/>	<u>BHM</u>	<u>7-1</u>
<input checked="" type="checkbox"/> P.C.B Masters	<u>All</u>	____	____	<input checked="" type="checkbox"/>	____	____
<input checked="" type="checkbox"/> P.C.B. Films	<u>All</u>	____	<input checked="" type="checkbox"/>	<input checked="" type="checkbox"/>	<u>BHM</u>	<u>7-1</u>
<input checked="" type="checkbox"/> Dimensional Diag.	____	____	____	____	____	____
____ Package Master Art	____	____	____	____	____	____
____ Package Films	____	____	____	____	____	____
____ Other: <u>AD-305 Parts</u>	<u>1</u>	<input checked="" type="checkbox"/>	<input checked="" type="checkbox"/>	____	<u>BHM</u>	<u>7-1</u>
____ Other: <u>AD-305 Assy.</u>	<u>1</u>	<input checked="" type="checkbox"/>	____	____	<u>BHM</u>	<u>7-1</u>

E.C.O. Completed and Filed By: B. Monahan Date: 8-18-83

Silkscreen Revisions

1. Add "Mix Vol." to RT2.
2. Add "+" for Tantalum Cap. C74.
3. Add "CN22", and Molex Block outline.
4. Add "C104" Ref. Des.
5. Move "SW1" Ref. Des.
6. Move "SW2" Ref. Des..
7. Move "LED1" Ref. Des.
8. Move "D12-D15" Ref. Des. and outlines.
9. Add Ref. Des. "3D, R83, 11E".
10. Add Ref. Des. and outline "R104".
11. Add Ref. Des. and outline "D54".
12. Change Rev# and date.
13. Remove "M2, M3, VR2, VR3" Ref. Des. and outlines.

Mechanical/Electrical Revisions

1. Remove "M2, M3, VR2, VR3" mounting holes.
2. Add "3 Pin" Molex Block for T03 Socket Cable. (CN22)
3. Board mount "C104, R104, D54".
4. Route shield trace from Pin #2 of IC #12A around trace from Pin #1 of IC #12A for shield purposes.
5. Remove Coaxial Cable.
6. Space Diodes "D12 - D15".
7. Revise Master Art to match Rev1 Film Kluges.

**E-mu Systems, Inc.**  
 applied magic for the arts

**ENGINEERING CHANGE ORDER**

E.C.O. No: 048  
 Date: 5/18/83 E.C.O. By: D. Rossum Approval: T.W.M. Chief Engineer: [Signature]  
 Confidential:      Customer Release: X  
 Affects Product: Drumulator Affects Assembly: Drumulator Bottom Panel DA-304, Rev 1  
 Serial Nos. Modified in Production: N/A  
 Notation to Modify Units in Repair: N/A  
 Approximate Starting Serial No. for New Documents: 878  
(visual check or call factory to verify)  
 P.C.B. Serial No. 637  
 Purpose of Change: Conform with Canadian import standards by changing ground lug configuration.

**PRIORITY OF CHANGE:**

For Future Units: X Modify Units in Production:       
 Modify all Units Available for Repair:      Modify All Field Units:     

**PARTS AFFECTED:**

Reference Designator		Description		Part Number	
Old	New	Old	New	Old	New

**\*\*FULL DESCRIPTION OF CHANGES ON REVERSE SIDE & ATTACHED DOCUMENTS\*\***

**FOR E-MU SYSTEMS, INC. USE ONLY:**

Documents Affected	Page No.	Deliver to Production	Deliver to Purchasing	Obsolete Copies Filed	Performed By	Date
<u>X</u>		<u>X</u>			<u>BHM</u>	<u>5/18</u>

E.C.O. Completed and Filed By: Brian H. Monahan Date: 5/18/83

E-E108-011-01



Schematic Diagram: Old

New

Mechanical Diagram: Old

1. Both GRN wires inserted into small hole of solder lug and soldered.
2. Solder lug mounted to mounting screw of transformer.

New

1. Both GRN wires stripped 1" and inserted through small hole in sold lug.

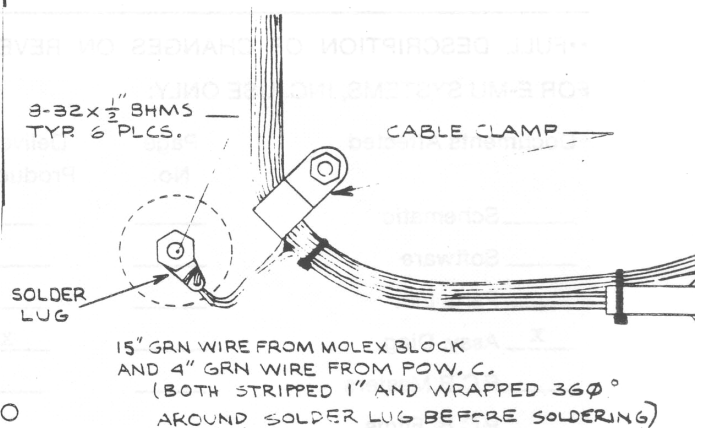

2. Then wrap wires 360 degrees around solder lug before soldering.
3. Mount solder lug to screw securing rubber foot to the left of the strain relief.

**E-mu Systems, Inc.**  
 applied magic for the arts

**ENGINEERING CHANGE ORDER**

Date: 8/23/83 E.C.O. By: B.H.M. Approval: T.W.M. Chief Engineer: [Signature]  
 E.C.O. No: 052

Confidential:  Customer Release:

Affects Product: Drumulator Affects Assembly: Rev. 1 PCB

Serial Nos. Modified in Production: Unit #1786

Notation to Modify Units in Repair: Replace all ITT (blue) capacitors at locations C60, C

Approximate Starting Serial No. for New Documents: \_\_\_\_\_  
(visual check or call factory to verify)

P.C.B. Serial No. 2466

Purpose of Change: Eliminate unreliable ITT 10uf 25 V. tantalum capacitors.  
Change parts descriptor to read "ITT capacitors unacceptable".  
Engineering recommends Sprague components.

**PRIORITY OF CHANGE:**

For Future Units:  Modify Units in Production:  (at PCB assembly level).

Modify all Units Available for Repair:  Modify All Field Units:  (if parts fail).

**PARTS AFFECTED:**

Reference Designator		Description				Part Number	
Old	New	Old	New		Old	New	
C60	-----	10uf 25V. tantalum	same		C-317	CT-317	
C61	-----	" "	" "		" "	" "	
C26	-----	" "	" "		" "	" "	
C74	-----	" "	" "		" "	" "	
*see below	-----	" "	" "		" "	" "	

\* Capacitor on T03 socket cable assembly.

**\*\*FULL DESCRIPTION OF CHANGES ON REVERSE SIDE & ATTACHED DOCUMENTS\*\***

**FOR E-MU SYSTEMS, INC. USE ONLY:**

Documents Affected	Page No.	Deliver to Production	Deliver to Purchasing	Obsolete Copies Filed	Performed By	Date
____ Schematic	____	____	____	____	____	____
____ Software	____	____	____	____	____	____
____ Parts List	____	____	____	____	____	____
____ Assy. Diag.	____	____	____	____	____	____
____ P.C.B Masters	____	____	____	____	____	____
____ P.C.B. Films	____	____	____	____	____	____
____ Dimensional Diag.	____	____	____	____	____	____
____ Package Master Art	____	____	____	____	____	____
____ Package Films	____	____	____	____	____	____
<input checked="" type="checkbox"/> Other: <u>Parts Descrip.</u>	____	____	<input checked="" type="checkbox"/>	____	<u>BHM</u>	<u>8/24/83</u>
<input checked="" type="checkbox"/> Other: <u>Parts master</u>	____	____	<input checked="" type="checkbox"/>	____	<u>TLM</u>	<u>8/24/83</u>

E.C.O. Completed and Filed By: Brian H. Monahan Date: 8/24/83

F-F106-044-01

**E-mu Systems, Inc.**  
 applied magic for the arts

**ENGINEERING CHANGE ORDER**

E.C.O. No: 053  
 Date: 9/6/83 E.C.O. By: Steve Davies Approval: [Signature] Chief Engineer: [Signature]  
 Confidential:  Customer Release:   
 Affects Product: Drumulator Affects Assembly: PCB  
 Serial Nos. Modified in Production: 1636-2763  
 Notation to Modify Units in Repair: See reverse  
 Approximate Starting Serial No. for New Documents: 2000  
(visual check or call factory to verify)  
 P.C.B. Serial No. 1673  
 Purpose of Change: To eliminate memory "fry" problem on Drumulators operated at 220 volts.

**PRIORITY OF CHANGE:**

For Future Units:  Modify Units in Production:   
 Modify all Units Available for Repair:  Modify All Field Units:

**PARTS AFFECTED:**

Reference Designator		Description		Part Number	
Old	New	Old	New	Old	New
none	C22	none previous	0,1 uf.	-----	CC-314
none	C105	none previous	0,01 uf. 1k V.	-----	CC-320

**\*\*FULL DESCRIPTION OF CHANGES ON REVERSE SIDE & ATTACHED DOCUMENTS\*\***

**FOR E-MU SYSTEMS, INC. USE ONLY:**

Documents Affected	Page No.	Deliver to Production	Deliver to Purchasing	Obsolete Copies Filed	Performed By	Date
<input checked="" type="checkbox"/> Schematic	<u>14</u>	<input checked="" type="checkbox"/>				
<input checked="" type="checkbox"/> Software						
<input checked="" type="checkbox"/> Parts List						
<input checked="" type="checkbox"/> Assy. Diag.						
<input checked="" type="checkbox"/> P.C.B Masters on rev 3						
<input checked="" type="checkbox"/> P.C.B. Films on rev 3						
<input checked="" type="checkbox"/> Dimensional Diag. on rev 3						

E.C.O. Completed and Filed By: \_\_\_\_\_ Date: \_\_\_\_\_

E-F106-044-01

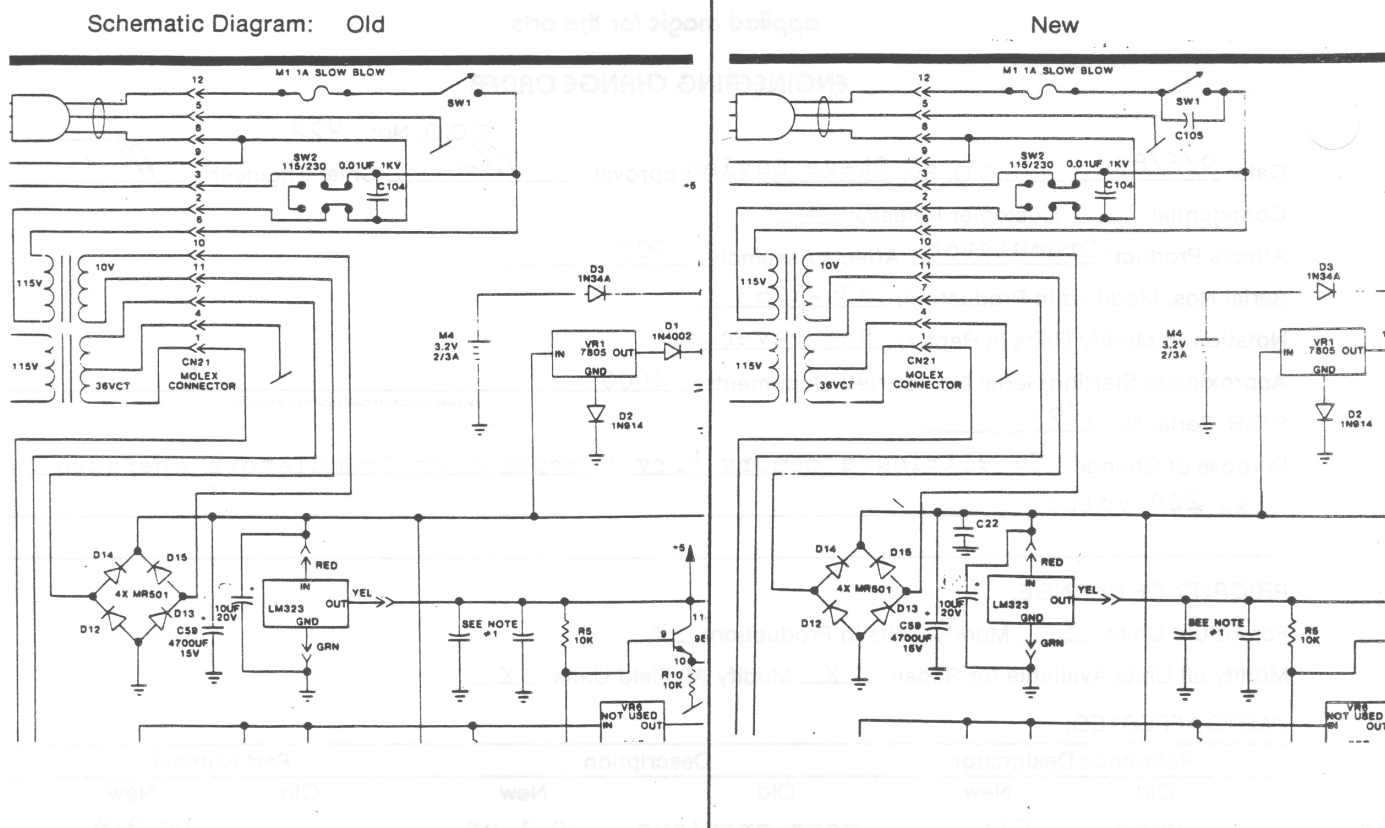

Mechanical Diagram:

1. Carefully desolder the power switch (SW1) and remove it from the PCB.
2. Solder a 0.01 uf, 1kV capacitor across the switch leads as shown.
3. Reinstall the switch in the PCB with the capacitor bent upwards so that when installed it will be perpendicular to the PCB.
4. Solder a 0.1 uf capacitor into the C22 location, (Note: pad layout is designed for a tantalum capacitor the ceramic capacitor will need to have the leads bent slightly to fit.)



Capacitor leads must be wrapped 360 degrees around switch leads and then soldered..

**E-mu Systems, Inc.**  
 applied magic for the arts

**ENGINEERING CHANGE ORDER**

E.C.O. No: 054

Date: 9-26-83 E.C.O. By: B.H.M. Approval: [Signature] Chief Engineer: [Signature]

Confidential: \_\_\_\_\_ Customer Release:

Affects Product: Drumulator Affects Assembly: PCB

Serial Nos. Modified in Production: See ECO 053

Notation to Modify Units in Repair: See reverse

Approximate Starting Serial No. for New Documents: See ECO 053

P.C.B. Serial No. See ECO 053 (visual check or call factory to verify)

Purpose of Change: Supplement to ECO 053 indicating alternate method of modification (method 1) to PCB.

**PRIORITY OF CHANGE:**

For Future Units:  Modify Units in Production: \_\_\_\_\_

Modify all Units Available for Repair: \_\_\_\_\_ Modify All Field Units: \_\_\_\_\_

PARTS AFFECTED: None

Reference Designator		Description		Part Number	
Old	New	Old	New	Old	New

**\*\*FULL DESCRIPTION OF CHANGES ON REVERSE SIDE & ATTACHED DOCUMENTS\*\***

**FOR E-MU SYSTEMS, INC. USE ONLY:**

Documents Affected	Page No.	Deliver to Production	Deliver to Purchasing	Obsolete Copies Filed	Performed By	Date
_____ Schematic	_____	_____	_____	_____	_____	_____
_____ Software	_____	_____	_____	_____	_____	_____
_____ Parts List	_____	_____	_____	_____	_____	_____
<input checked="" type="checkbox"/> Assy. Diag.	<u>1</u>	<input checked="" type="checkbox"/>	_____	_____	<u>bhm</u>	<u>9/26/83</u>
_____ P.C.B Masters	_____	_____	_____	_____	_____	_____
_____ P.C.B. Films	_____	_____	_____	_____	_____	_____
_____ Dimensional Diag.	_____	_____	_____	_____	_____	_____
_____ Package Master Art	_____	_____	_____	_____	_____	_____
_____ Package Films	_____	_____	_____	_____	_____	_____
_____ Other: _____	_____	_____	_____	_____	_____	_____
_____ Other: _____	_____	_____	_____	_____	_____	_____

E.C.O. Completed and Filed By: BHM Date: 9/26/83

E-E106-044-01



**E-mu Systems, Inc.**  
applied magic for the arts

**ENGINEERING CHANGE ORDER**

E.C.O. No: 056  
 Date: 10-6-83 E.C.O. By: B.H.M. Approval: [Signature] Chief Engineer: [Signature]  
 Confidential:      Customer Release: X  
 Affects Product: Drumulator Affects Assembly: PCB  
 Serial Nos. Modified in Production: N/A  
 Notation to Modify Units in Repair: See doc. # A-7501-011-02  
 Approximate Starting Serial No. for New Documents: 2800  
 P.C.B. Serial No. 2500 (visual check or call factory to verify)  
 Purpose of Change: To raise polystyrene capacitors 0.10 inches above PCB  
to eliminate possibility of capacitors melting during soldering stage.

**PRIORITY OF CHANGE:**

For Future Units: X Modify Units in Production: @  
 Modify all Units Available for Repair: @ Modify All Field Units: @  
@ if required.

**PARTS AFFECTED:**

Reference Designator		Description		Part Number	
Old	New	Old	New	Old	New
C29-C36		2200 pf	-----	CP-308	-----
_____	_____	_____	_____	_____	_____
_____	_____	_____	_____	_____	_____
_____	_____	_____	_____	_____	_____
_____	_____	_____	_____	_____	_____

**\*\*FULL DESCRIPTION OF CHANGES ON REVERSE SIDE & ATTACHED DOCUMENTS\*\***

**FOR E-MU SYSTEMS, INC. USE ONLY:**

Documents Affected	Page No.	Deliver to Production	Deliver to Purchasing	Obsolete Copies Filed	Performed By	Date
_____ Schematic	_____	_____	_____	_____	_____	_____
_____ Software	_____	_____	_____	_____	_____	_____
_____ Parts List	_____	_____	_____	_____	_____	_____
<u>X</u> Assy. Diag.	<u>1</u>	<u>X</u>	_____	_____	<u>B.H.M.</u>	<u>10-6-83</u>
_____ P.C.B Masters	_____	_____	_____	_____	_____	_____
_____ P.C.B. Films	_____	_____	_____	_____	_____	_____
_____ Dimensional Diag.	_____	_____	_____	_____	_____	_____
_____ Package Master Art	_____	_____	_____	_____	_____	_____
_____ Package Films	_____	_____	_____	_____	_____	_____
_____ Other: _____	_____	_____	_____	_____	_____	_____
_____ Other: _____	_____	_____	_____	_____	_____	_____

E.C.O. Completed and Filed By: Brian H. Monahan Date: 10-6-83

E-E106-044-01

**E-mu Systems, Inc.**  
applied magic for the arts

**ENGINEERING CHANGE ORDER**

E.C.O. No: 057

Date: 10-6-83 E.C.O. By: K.J.M. Approval: ML Chief Engineer: ML

Confidential:  Customer Release:

Affects Product: Drumulator Affects Assembly: PCB

Serial Nos. Modified in Production: 2800

Notation to Modify Units in Repair: See reverse

Approximate Starting Serial No. for New Documents: 3000

P.C.B. Serial No. 2500

(visual check or call factory to verify)

Purpose of Change: To allow metronome and clock outputs to interface with other manufacturers products.

**PRIORITY OF CHANGE:**

For Future Units:  Modify Units in Production:

Modify all Units Available for Repair:  Modify All Field Units:

**PARTS AFFECTED:**

Reference Designator		Description		Part Number	
Old	New	Old	New	Old	New
<u>C74</u>	<u>same</u>	<u>10 uf 10v tant</u>	<u>buss wire jmp.</u>	<u>CT317</u>	<u>WW129</u>
<u>C75</u>	<u>same</u>	<u>0.1 uf</u>	<u>buss wire jmp.</u>	<u>CC314</u>	<u>WW129</u>

**\*\*FULL DESCRIPTION OF CHANGES ON REVERSE SIDE & ATTACHED DOCUMENTS\*\***

**FOR E-MU SYSTEMS, INC. USE ONLY:**

Documents Affected	Page No.	Deliver to Production	Deliver to Purchasing	Obsolete Copies Filed	Preformed By	Date
<input checked="" type="checkbox"/> Schematic	<u>2</u>					
Software						
<input checked="" type="checkbox"/> Parts List	<u>1</u>	<input checked="" type="checkbox"/>	<input checked="" type="checkbox"/>		<u>B.H.M.</u>	<u>10-6-83</u>
<input checked="" type="checkbox"/> Assy. Diag.	<u>1</u>	<input checked="" type="checkbox"/>	<input checked="" type="checkbox"/>		<u>B.H.M.</u>	<u>10-6-83</u>
P.C.B. Masters						
P.C.B. Films						
Dimensional Diag.						
Package Master Art						
Package Films						
Other: _____						
Other: _____						

E.C.O. Completed and Filed By: Brian H. Monahan Date: 10-6-83

E-E108-011-01



Schematic Diagram: Old

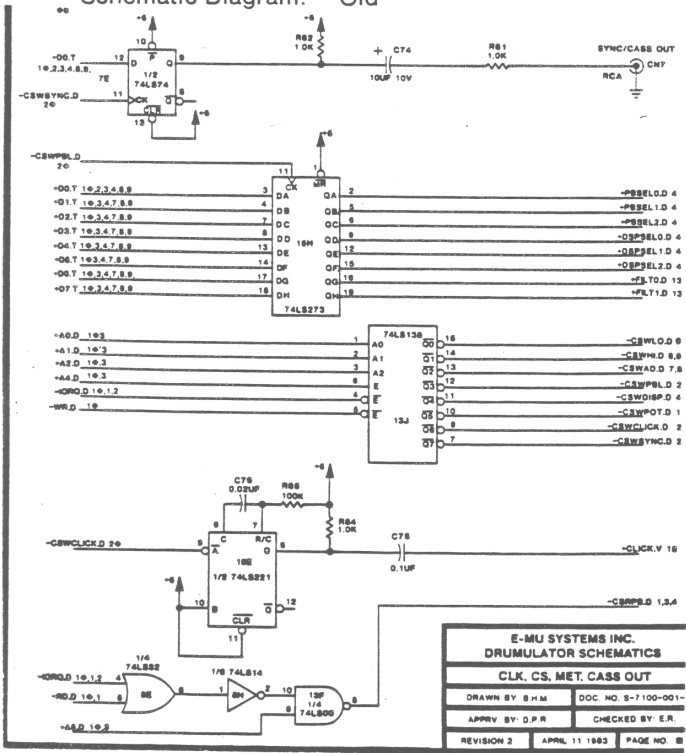

New

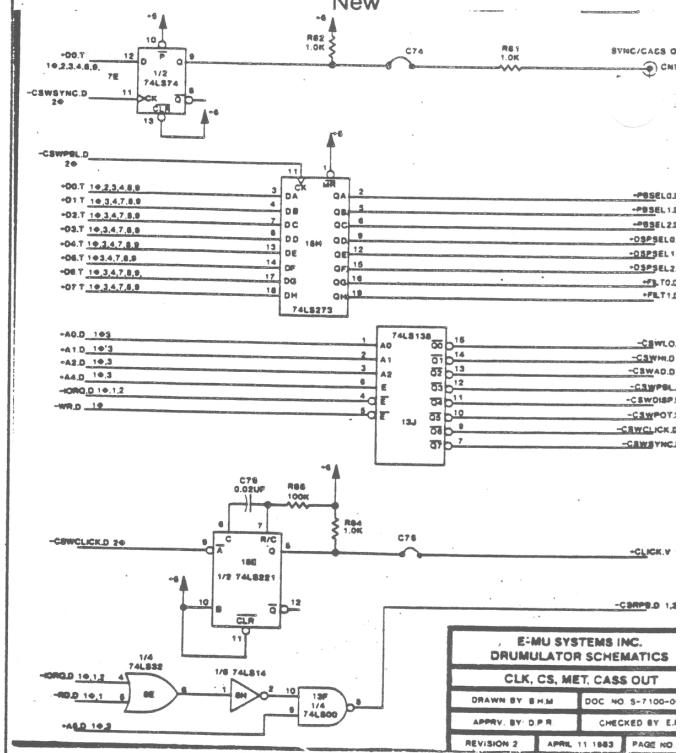

Mechanical Diagram: Old

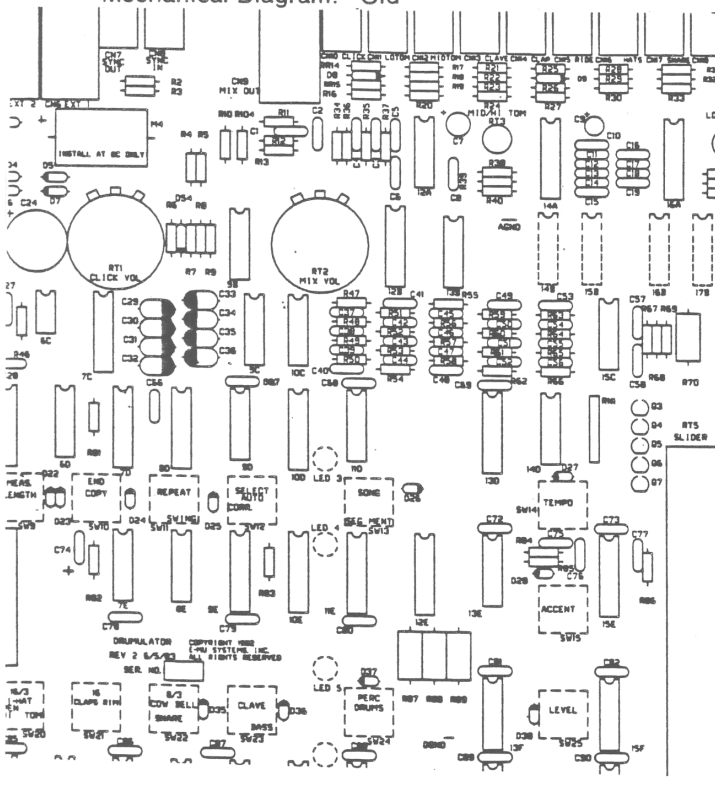

New

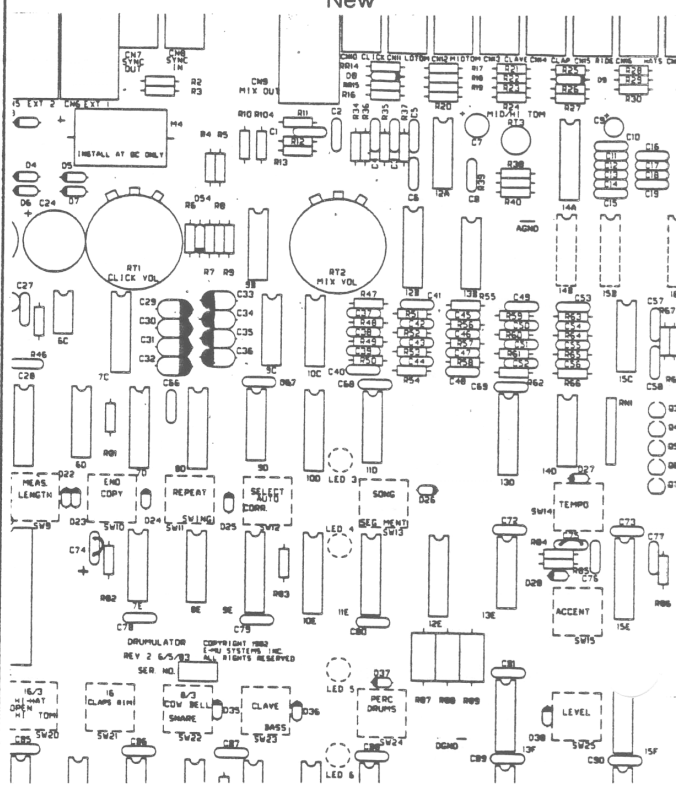

**E-mu Systems, Inc.**  
applied magic for the arts

**ENGINEERING CHANGE ORDER**

E.C.O. No: 058

Date: 10-7-83 E.C.O. By: D.P. R. Approval: [Signature] Chief Engineer: [Signature]

Confidential:  Customer Release:  X

Affects Product: Drumulator Affects Assembly: P.C.B.

Serial Nos. Modified in Production: N/A

Notation to Modify Units in Repair: N/A

Approximate Starting Serial No. for New Documents: \_\_\_\_\_  
(visual check or call factory to verify)

P.C.B. Serial No. \_\_\_\_\_

Purpose of Change: Update software per software revision notice #8.  
Adds 64 song capability and song edit mode.

**PRIORITY OF CHANGE:**

For Future Units:  X Modify Units in Production:

Modify all Units Available for Repair:  Modify All Field Units:  @  
@ Make update kits available for field service centers.

**PARTS AFFECTED:**

Reference Designator		Description		Part Number	
Old	New	Old	New	Old	New
12K	same	p1.05 830405	P2.00 831006	IM333	same
_____	_____	_____	_____	_____	_____
_____	_____	_____	_____	_____	_____
_____	_____	_____	_____	_____	_____
_____	_____	_____	_____	_____	_____

**\*\*FULL DESCRIPTION OF CHANGES ON REVERSE SIDE & ATTACHED DOCUMENTS\*\***

**FOR E-MU SYSTEMS, INC. USE ONLY:**

Documents Affected	Page No.	Deliver to Production	Deliver to Purchasing	Obsolete Copies Filed	Preformed By	Date
_____ Schematic	_____	_____	_____	_____	_____	_____
<u>X</u> Software	_____	<u>X</u>	<u>X</u>	<u>X</u>	<u>DPR</u>	<u>10-7-83</u>
<u>X</u> Parts List	_____	_____	_____	_____	_____	_____
_____ Assy. Diag.	_____	_____	_____	_____	_____	_____
_____ P.C.B Masters	_____	_____	_____	_____	_____	_____
_____ P.C.B. Films	_____	_____	_____	_____	_____	_____
_____ Dimensional Diag.	_____	_____	_____	_____	_____	_____
_____ Package Master Art	_____	_____	_____	_____	_____	_____
_____ Package Films	_____	_____	_____	_____	_____	_____
<u>X</u> Other: <u>Label spec.</u>	<u>1</u>	<u>X</u>	<u>X</u>	<u>X</u>	<u>BHM</u>	<u>10-10-83</u>
<u>X</u> Other: <u>Owners Manual all</u>	_____	_____	_____	_____	<u>MMA</u>	<u>10-10-83</u>

E.C.O. Completed and Filed By: Brian H. Monahan Date: 10-10-83

E-E106-044-01

E-MU SYSTEMS, INC. - SOFTWARE RELEASE NOTICE

DATE 10/6/83

PRODUCT DRUMULATOR

SRN S/N 8

THIS REVISION NUMBER & DATE CODE P2.00 831006

OLD REVISION NUMBER & DATE CODE P1.05

REASON FOR REVISION: Add 64 song capability and Song Edit Enable

CHANGES IMPLEMENTED: Numerous changes to implement these features, and economize use of memory.

BUGS FIXED: None

KNOWN BUGS: Any Song in continuous loop with no segments can only be stopped by turning off machine

M APPROVAL OF CHIEF WIZARD

- UPDATED LISTINGS FILED
- DISK ARCHIVES UPDATED
- PRODUCTION GIVEN OBJECT CODE
- PURCHASING GIVEN OBJECT CODE
- ECO ISSUED - ECO NUMBER 058

REV 830510

**E-mu Systems, Inc.**  
 applied magic for the arts

**ENGINEERING CHANGE ORDER**

E.C.O. No: 062

Date: 3/29/84 E.C.O. By: Swift/Sheehan Approval: \_\_\_\_\_ Chief Engineer: [Signature]

Confidential: \_\_\_\_\_ Customer Release:

Affects Product: Drumulator Affects Assembly: PCB

Serial Nos. Modified in Production: PCB Serial# 4904 - 6957

Notation to Modify Units in Repair: See Reverse

Approximate Starting Serial No. for New Documents: Drumulator Serial# 4914  
(visual check or call factory to verify)

P.C.B. Serial No. 4904

Purpose of Change: Erratic Reset Conditions on power up caused by current PWR RST CKT. Addition of capacitor insures 3 clock cycle. Reset for Z80 & produces a flywheel effect on the RST CKT.

**PRIORITY OF CHANGE:**

For Future Units:  Modify Units in Production:

Modify all Units Available for Repair:  Modify All Field Units: \_\_\_\_\_

**PARTS AFFECTED:**

Reference Designator		Description		Part Number	
Old	New	Old	New	Old	New
None	C106	None	.1uF Cer cap	None	CC-314
_____	_____	_____	_____	_____	_____
_____	_____	_____	_____	_____	_____
_____	_____	_____	_____	_____	_____
_____	_____	_____	_____	_____	_____

**\*\*FULL DESCRIPTION OF CHANGES ON REVERSE SIDE & ATTACHED DOCUMENTS\*\***

**FOR E-MU SYSTEMS, INC. USE ONLY:**

Documents Affected	Page No.	Deliver to Production	Deliver to Purchasing	Obsolete Copies Filed	Preformed By	Date
<input checked="" type="checkbox"/> Schematic	<u>14</u>	<input checked="" type="checkbox"/>	<input checked="" type="checkbox"/>	<input checked="" type="checkbox"/>	<u>MR</u>	<u>3/30</u>
_____ Software	_____	_____	_____	_____	_____	_____
<input checked="" type="checkbox"/> Parts List	<u>ALL</u>	<input checked="" type="checkbox"/>	<input checked="" type="checkbox"/>	<input checked="" type="checkbox"/>	<u>MR</u>	<u>3/30</u>
<input checked="" type="checkbox"/> Assy. Diag.	<u>1</u>	<input checked="" type="checkbox"/>	<input checked="" type="checkbox"/>	<input checked="" type="checkbox"/>	<u>MR</u>	<u>3/30</u>
<input checked="" type="checkbox"/> P.C.B Masters	<u>ALL</u>	<input checked="" type="checkbox"/>	<input checked="" type="checkbox"/>	<input checked="" type="checkbox"/>	<u>MR</u>	<u>3/30</u>
<input checked="" type="checkbox"/> P.C.B. Films	<u>ALL</u>	<input checked="" type="checkbox"/>	<input checked="" type="checkbox"/>	<input checked="" type="checkbox"/>	<u>MR</u>	<u>3/30</u>
_____ Dimensional Diag.	_____	_____	_____	_____	_____	_____
_____ Package Master Art	_____	_____	_____	_____	_____	_____
_____ Package Films	_____	_____	_____	_____	_____	_____
_____ Other: _____	_____	_____	_____	_____	_____	_____
_____ Other: _____	_____	_____	_____	_____	_____	_____

E.C.O. Completed and Filed By: Monique Redelfs Date: 3/30/84

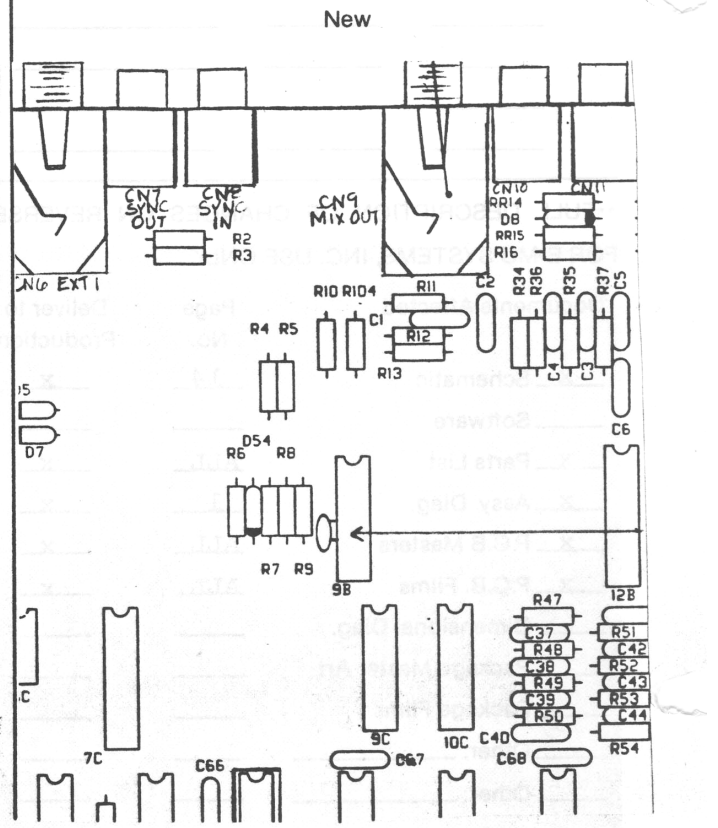
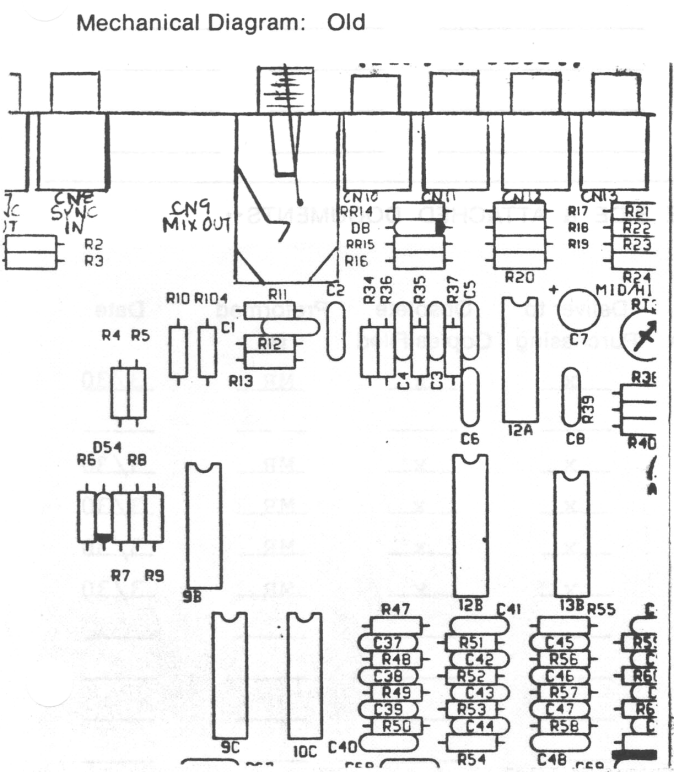
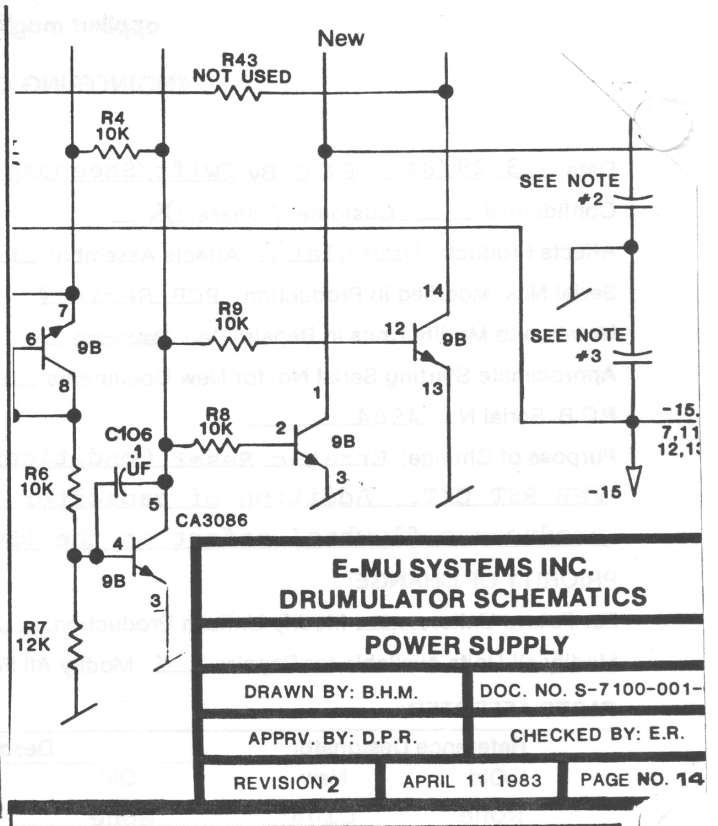
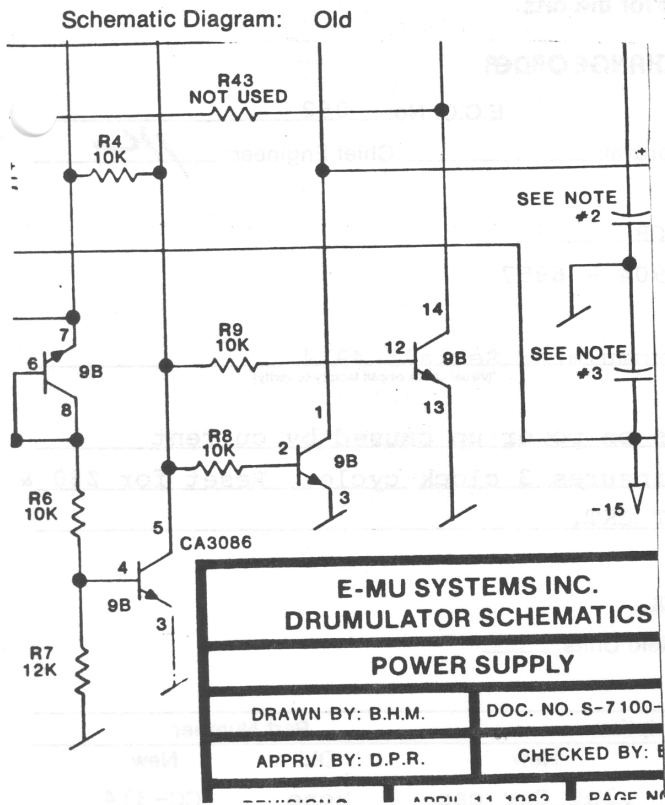

# 10

# Service Centers

---

(8/83 servcen)

Service Centers  
United States & Canada

California

Advanced Musical Electronics (Jack or Chris)  
2122-A S. Sepulveda Blvd.  
West Los Angeles, CA 90025  
213-478-0589

CAE  
1150 E. Santa Inez  
San Mateo, CA 94401  
415-348-2737

Hi-Tech Musical Services (Jim Cooper)  
2800 Washington Blvd.  
Marina del Rey, CA 90291  
213-827-3768

Musicians Repair Service  
3089 54th St.  
San Diego, CA 92105  
619-583-7851

Shultz Sound Design (Dave Shultz)  
9542 Pollack  
Huntington Beach, CA 92646  
714-964-5044

Canada

Sound Box (Paul Dugas)  
5030 W. Sherbrooke  
Montreal, Quebec H4A 157  
514-489-6851

Steve's Music  
415 Queen St. West  
Toronto, Ontario H2Z 1G9  
514-878-2216

Colorado

Keyboard Exchange  
353 S. Sheridan  
Denver, CO 80226  
303-988-9090

Florida

Discount Music Center (Randy)  
456 N. Orange Ave.  
Orlando, FL 32801  
305-843-2025

Georgia

Wizard Electronics (Cole Harrison)  
1438 Tullie Rd.  
Atlanta, GA 30329  
404-325-4891

Illinois

Music Dealer Service (Tom)  
4700 W. Fullerton  
Chicago, IL 60639  
312-282-8171

Kansas

Alternative Sound (Ed Jeffries)  
9303 Johnson  
Merriam, KS 66203  
913-677-0433

Louisiana

Allied Music  
4417 Bienville Ave.  
New Orleans, LA 70119  
504-488-0319

Massachusetts

Rivera Music Center (Ron Rivera)  
77 Hartford St.  
Newton Highlands, MA 02161  
617-964-0943

Michigan

Arnoldt Williams  
5701 Canton Center Rd.  
Canton, MI 48187  
313-453-6586

Marshall Music  
540 Prandor Shopping Center  
Lansing, MI 48912  
517-337-9700

Minnesota

The Good Guys (Mark or Quint)  
1111 Grand Ave.  
St. Paul, MN 55110  
612-292-9165

New York Acutone  
898 A Broadway  
Massapenqua, NY  
516-799-3104

Nevada

The Service Center (John Kaufman)  
2675 Oddie  
Reno, NV 98500  
702-356-1067

New Jersey

Triple S. Electronics (Marty)  
322 Washington St.  
Belleville, NJ 07109  
201-751-0481

Ohio

Pi Corp  
13329 Pearl Rd.  
Cleveland, OH 44136  
216-238-0644

Oklahoma

Richard Bugg  
2703 N.W. 20th  
Oklahoma City, OK  
405-943-0940

Utah

Guitar City Studios (Kip)  
470 N. 1100 West  
Centerville, UT 84014  
801-292-8461

Washington

Petosa Music (Dean)  
313 N.E. 45th St.  
Seattle, WA 98105  
206-632-2700





## 12 Drumulator Pad Programmer Operating Instructions

---

### Introduction

Your Drumulator Pad Programmer allows you to program the Drumulator (or other drum machines with standard CMOS 5V trigger inputs) in real time with ordinary drum sticks. Each of the Pad Programmer's four pads can be assigned to any Drumulator sound. The sensitivity of each pad can be individually adjusted to match your particular playing style. In addition, four trigger inputs allow programming from other external pads or control voltage sources.

### Set up

Place the Pad Programmer on a flat surface near your Drumulator. You will need four interconnecting cables, each with an RCA phono plug on one end and a standard 1/4" phone plug on the other. Plug the RCA plugs into the Trigger Out jacks on the rear of the Pad Programmer. Plug the 1/4" phone plugs into the corresponding Gate jacks on the rear of the Drumulator (i.e. Trigger Out "A" to Gate "A", Trigger out "B" to Gate "B", etc.)

Plug the mini-plug on the included AC power adapter into the Power jack on the rear of the Pad Programmer. Plug the AC adapter transformer into a standard AC outlet.

### Assigning Sounds to Pads

The Pad Programmer's pads are labeled A, B, C, and D. They correspond to play buttons A, B, C, and D on the Drumulator. Assigning a sound to a Drumulator Play button assigns the same sound to the corresponding pad on the Pad Programmer (e.g. assigning the snare sound to Play button A allows you to play the snare on pad A.) Assigning an accented sound to a Play button also assigns the accented sound to the corresponding pad.

### Adjusting Pad Sensitivity

The trigger threshold of each pad (i.e. how hard you have to hit the pad in order to have it cause the Drumulator to make a sound) is set with the sensitivity trimmers accessible through the rear of the Pad Programmer. Turning a trimmer wheel to the right (clockwise) decreases sensitivity (you'll have to hit the pad harder) while turning it to the left (counterclockwise) increases sensitivity.

The object in adjusting each pad is to get the maximum sensitivity that doesn't result in "crosstalk". Crosstalk occurs when you hit a pad so hard that the impact is transmitted to an adjacent pad, causing it to trigger. By properly adjusting each pad, crosstalk can be eliminated in all but the most extreme cases. The actual adjustment depends on your playing style. If you play with a light touch, the sensitivity can be set rather high. If, on the other hand, you typically pound your drums into submission, a lower sensitivity level is called for.

To set pad A's sensitivity, start by turning trimmer A fully clockwise (lowest sensitivity). Now, while hitting an *adjacent* pad (e.g. pad B) as hard as you typically play (be honest!) turn trimmer A counterclockwise, increasing the sensitivity, until crosstalk occurs (i.e. pad A triggers in response to you hitting pad B). At this point turn trimmer A slightly clockwise, just to the point at which crosstalk no longer occurs. Repeat this procedure for each of the three remaining pads.

By observing the LED associated with each pad, it is even possible to adjust sensitivity without having to listen to the Drumulator.

### Programming the Drumulator

Once you have set up your Pad Programmer and adjusted the pad's sensitivity, programming the Drumulator is simply a matter of hitting the pads while the Drumulator is in Record mode. The pads are functionally identical to the Drumulators four Play buttons and both the pads and buttons are active at all times.

### Using the Pad Programmer With a Drum Machine Other Than the Drumulator

Since the Pad Programmer's trigger out jacks supply standard 5V Gates, the Pad Programmer can trigger any other device that will accept such signals. Adapter cables may have to be fabricated depending on the connector(s) used on the device to be controlled. If the device has more than four trigger inputs, multiple Pad Programmers may be connected simultaneously.

**Using the External Sensor Inputs**

The four external sensor inputs allow the use of some external pad controllers. These inputs require a voltage similar to that supplied by the piezo-electric transducers used in the Pad Programmer. Trial and error is probably the best method of determining which controllers will and won't work. The sensitivity trimmers will almost certainly have to be recalibrated when using external controllers.

**In Case It Doesn't Seem to Work**

If your Pad Programmer doesn't seem to be working right, first check your Drumulator to be sure *it's* functioning correctly. If it is, refer to the following list of possible problems:

<b>Symptom</b>	<b>Possible Problems</b>
Pad(s) do not respond to being hit (no sound, LED doesn't light)	AC power adapter not properly connected. Pad sensitivity set too low.
LED lights when pad hit, but no sound	Pad not connected to Drumulator. Bad interconnection cable. Level of the sound assigned to the pad is set to 0.
Hitting pad triggers wrong sound	Sounds misassigned to Drumulator play buttons. Interconnection cables misconnected. (i.e. "A" to "B", "C" to "A", etc.)

If after checking the above, the problem persists, your Pad Programmer is probably broken. Contact your nearest E-mu authorized service center for help.

Have Fun!  
E-mu Systems

**Pad Programmer - Theory of Operation -**

**Revision of 2/27/84**

The Pad Programmer consists of four independent trigger sensors with appropriate circuitry, with a common housing and power supply.

The power supply is a simple three terminal regulator +5V supply. The input voltage is between 8 and 25 VDC and the current requirements are small enough (around 40 mA when an LED is firing, less quiescently) that heat sinking is not required. The plug in wall unit supplies nominally 10 VDC which is filtered and regulated.

The sensor is a piezo-electric crystal mounted in a housing designed to transmit pressure from a vertical strike by a drumstick, and attenuate vibrations conducted by the housing. This assembly is glued together and tested at the factory. Service on these assemblies will generally be by replacement, as repairs are difficult to accomplish and will frequently be unreliable.

The sensor produces a substantial voltage spike (10-100+ volts), which is loaded by a parallel capacitor and resistor, and rectified by a full wave bridge. The resulting positive voltage is attenuated and applied to one terminal of a comparator. The other terminal of the comparator is adjusted for the desired sensitivity threshold. The trim range is set to stay within the common mode range of the comparator. Positive feedback around the comparator is provided to minimize marginal switching. The comparator output triggers a one-shot which will both swallow any comparator oscillation or multiple triggering, and provide sufficient pulse width for the LED amplifier and for the output trigger pulse. Both of these signals are buffered from the one-shot output.

For information on adjusting the sensitivity trims, refer to the Pad Programmer User's Guide.

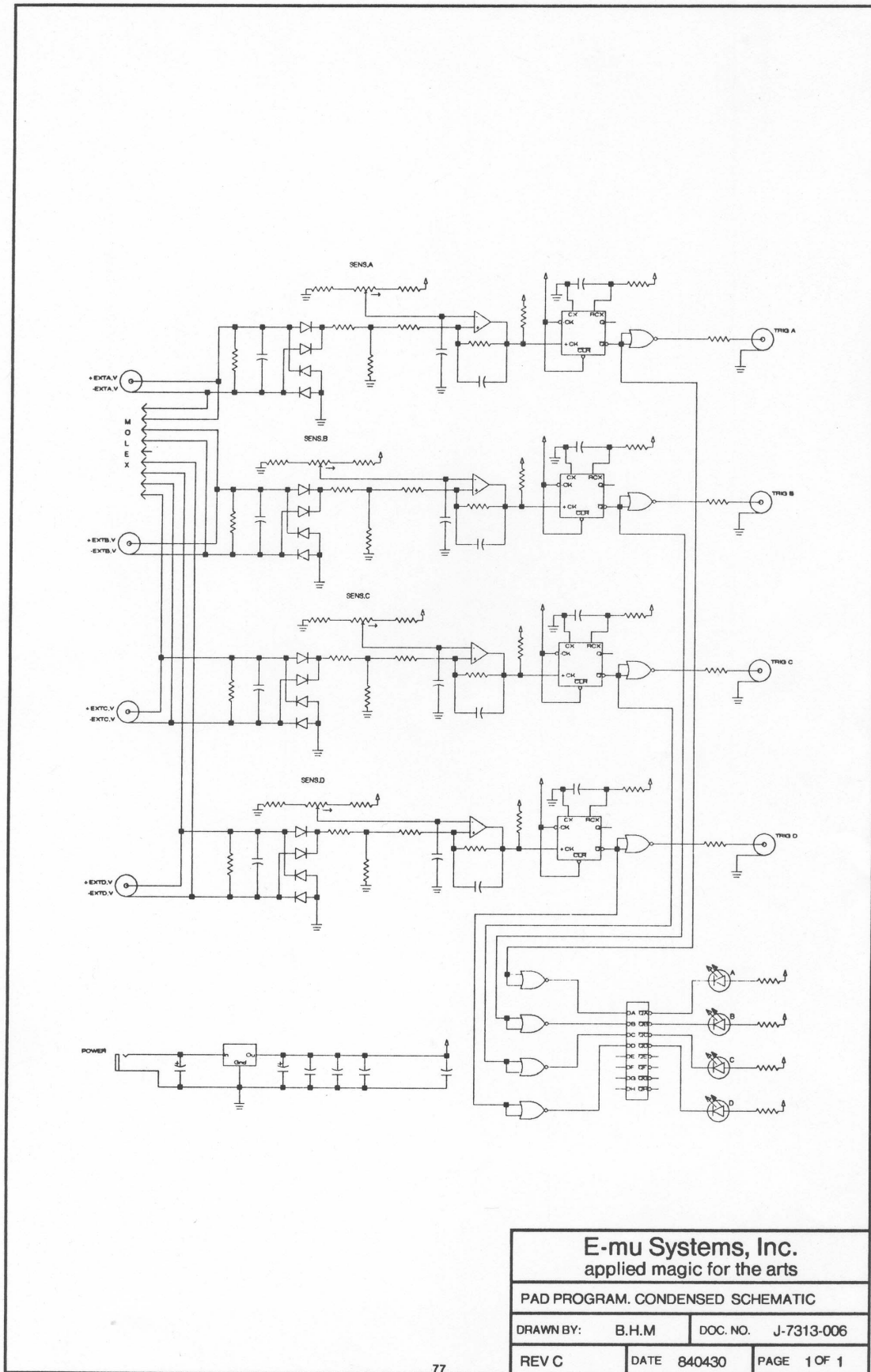

<b>E-mu Systems, Inc.</b> applied magic for the arts		
PAD PROGRAM. CONDENSED SCHEMATIC		
DRAWN BY:	B.H.M	DOC. NO. J-7313-006
REV C	DATE 840430	PAGE 1 OF 1

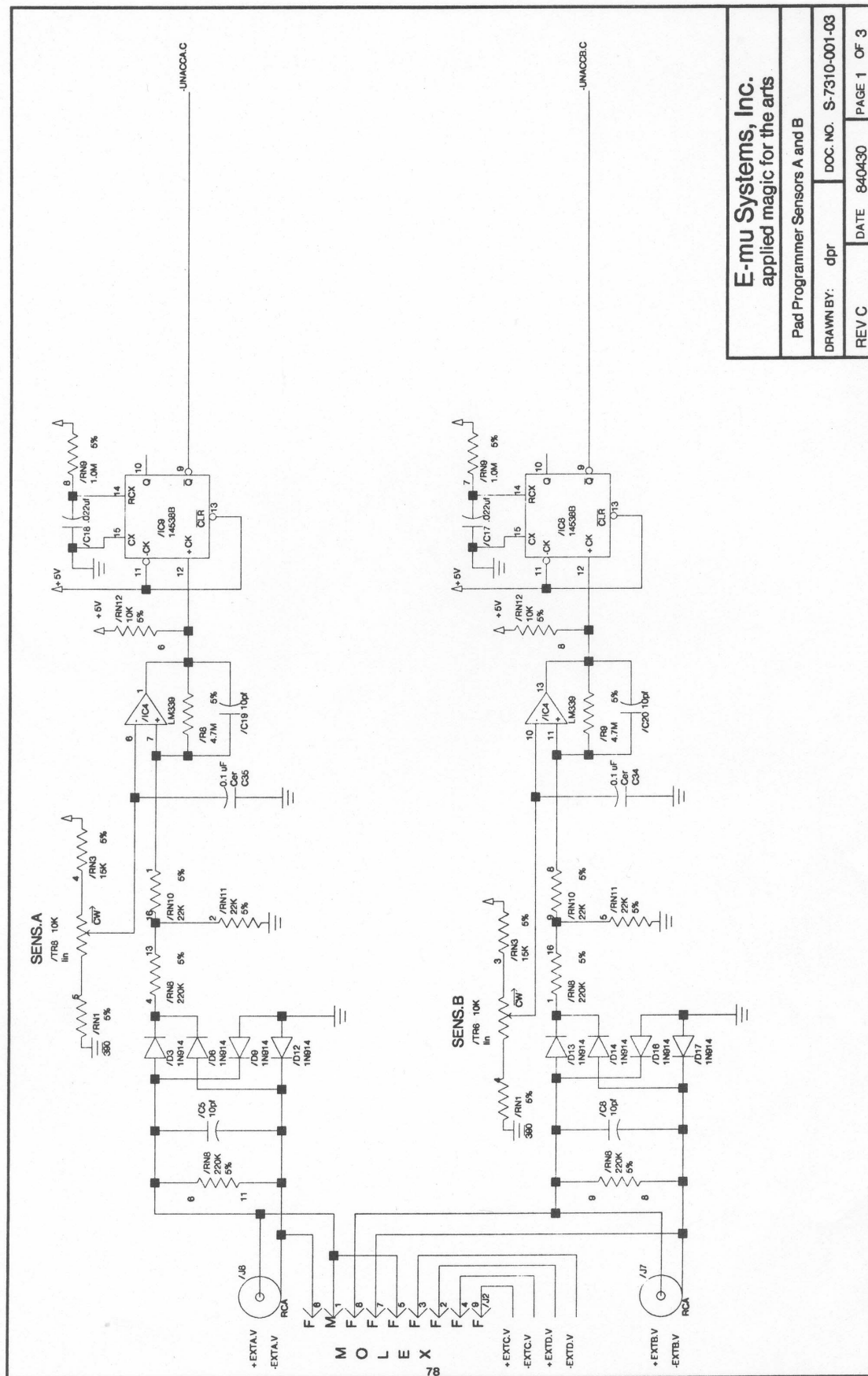

<b>E-mu Systems, Inc.</b> applied magic for the arts			
Pad Programmer Sensors A and B			
DRAWN BY:	dpr	DOC. NO.	S-7310-001-03
REV C	DATE	840430	PAGE 1 OF 3



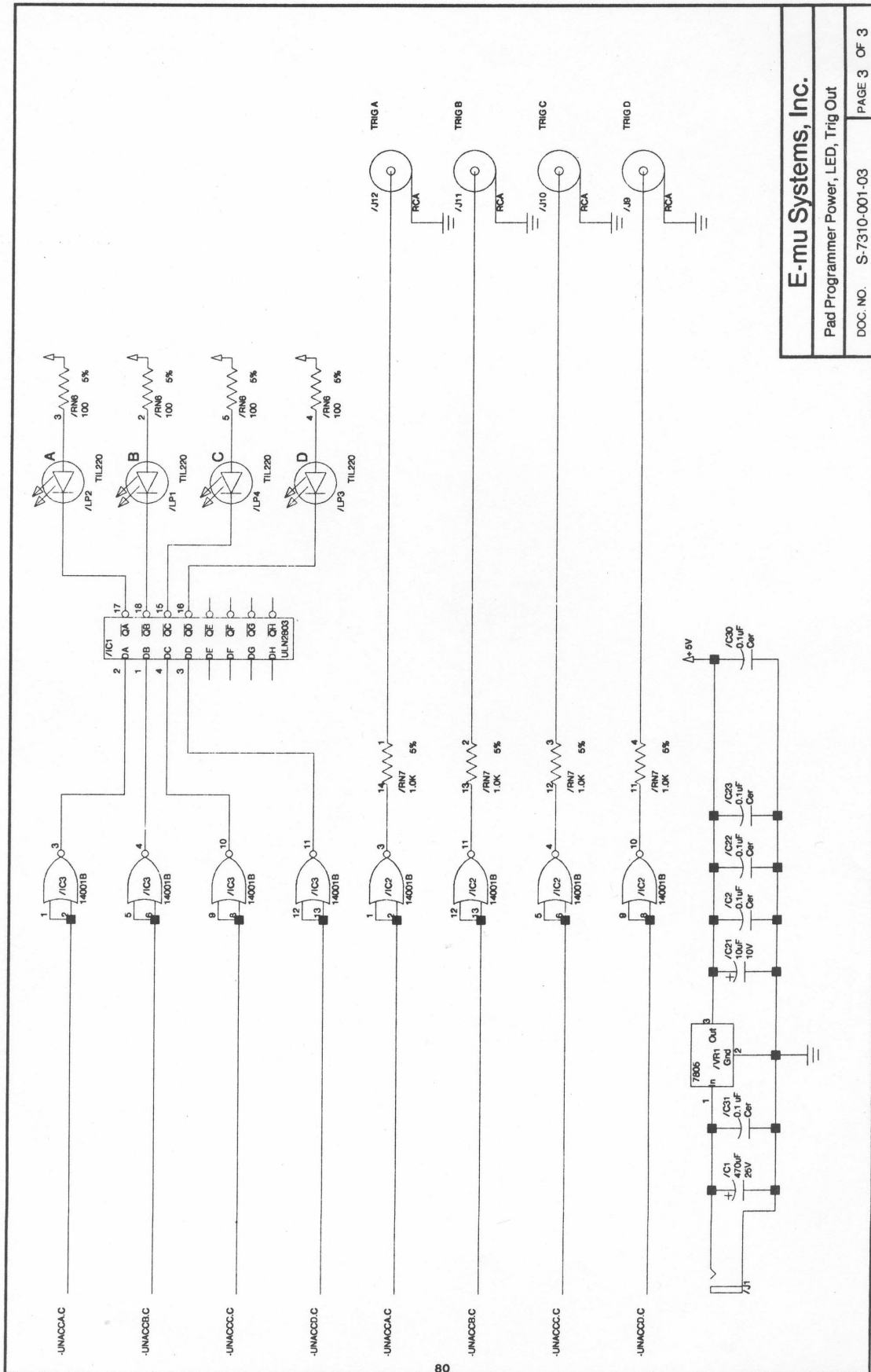

<b>E-mu Systems, Inc.</b>	
Pad Programmer Power, LED, Trig Out	
DOC. NO. S-7310-001-03	PAGE 3 OF 3